

VIVOIL

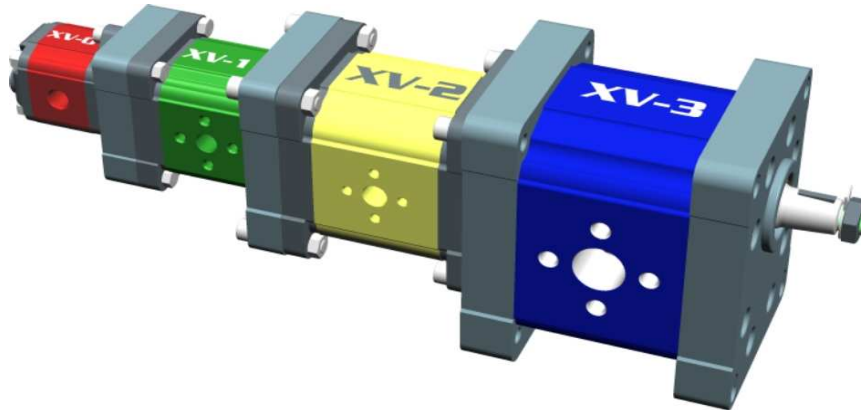

ENGLISH

Reversible Motors



XV-0P	Unidirectional Pump	
XV-1P	Left Rotation	Right Rotation
XV-2P		
XV-3P		

XV-0U	Unidirectional Motor	
XV-1U	Left Rotation	Right Rotation
XV-2U		
XV-3U		

XV-0R	Reversible Pump	
XV-1R	External drainage	Internal drainage
XV-2R		
XV-3R		

XV-0M	Reversible Motor	
XV-1M	External drainage	Internal drainage
XV-2M		
XV-3M		

XV-0T	XV-1T	XV-2T	XV-3T	Primary element of multiple pump
XV-0I	XV-1I	XV-2I	XV-3I	Intermediate element of multiple pump
XV-0F	XV-1F	XV-2F	XV-3F	Final element of multiple pump

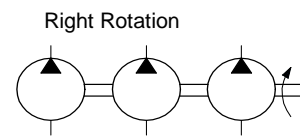
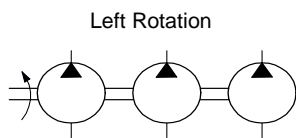

KV-DF	Flow divider
--------------	---------------------

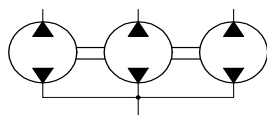

KV-DFV	Flow divided with valves
---------------	---------------------------------

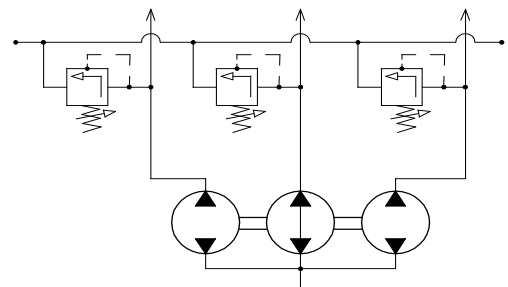

KV-DF+M	Flow divider with motor
----------------	--------------------------------

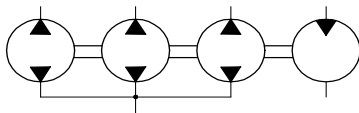

The descriptions and dimensions stated herein are not binding. Vivoil Oleodinamica Vivolo s.r.l reserves the right to make changes as it deems necessary, at any time and without notice.

Introduction	7
Summary: Displacements - Pressures - Speeds	9
General technical data	10
Torques allowed on shaft	12
Useful calculation formulas	13
Characteristic Curves	14

XV-0M

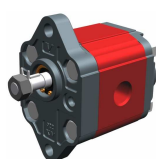

XM001

STANDARD MOTOR

ø22 FLANGE - PARALLEL SHAFT

18



XM012

BH TYPE MOTOR

ø22 BODY-SHAPED FLANGE - MILLED SHANK

20

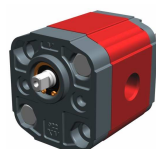

XM017

HY TYPE MOTOR

ø22 BODY-SHAPED FLANGE - MILLED SHANK

22

XV-1M



XM101

STANDARD EUROPEAN MOTOR

ø25.4 FLANGE - TAPER SHAFT

24

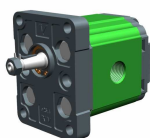

XM105

STANDARD EUROPEAN MOTOR

ø25.4 FLANGE - TAPER SHAFT

26

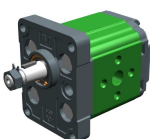

XM113

STANDARD MOTOR

ø30 FLANGE - TAPER SHAFT

28



XM119

BH TYPE MOTOR

ø32 BODY-SHAPED FLANGE - MILLED SHANK

30



XM140

HY TYPE MOTOR

ø32 BODY-SHAPED FLANGE - MILLED SHANK

32



XM161

STANDARD GERMAN "BH" TYPE MOTOR

ø32 BODY-SHAPED FLANGE - MILLED SHANK

34

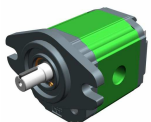

XM168

SAE AA TYPE MOTOR

ø50.8 FLANGE - PARALLEL SHAFT

36

XV-2M

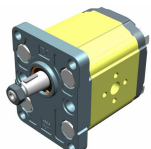

XM201

STANDARD EUROPEAN MOTOR

ø36.5 FLANGE - TAPER SHAFT

38

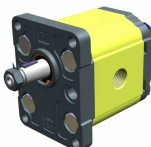

XM207

STANDARD EUROPEAN MOTOR

ø36.5 FLANGE - TAPER SHAFT

40

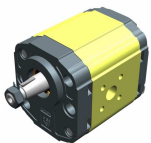

XM210

BH TYPE MOTOR

ø50 BODY-SHAPED FLANGE - TAPER SHAFT

42

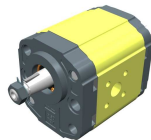

XM213

HY TYPE MOTOR

ø50 BODY-SHAPED FLANGE - TAPER SHAFT

44

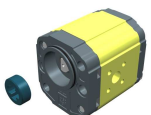

XM216

STANDARD GERMAN "BH" TYPE MOTOR

ø52 BODY-SHAPED FLANGE - MILLED SHANK

46

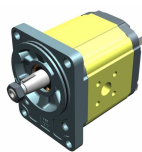

XM217

STANDARD GERMAN MOTOR
ø80 FLANGE - TAPER SHAFT

48



XM219

SAE A TYPE MOTOR
ø82.5 FLANGE - SPLINED SHAFT

50

XV-3M

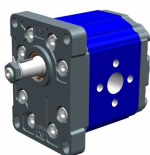

XM301

STANDARD EUROPEAN MOTOR
ø50.8 FLANGE - TAPER SHAFT

52

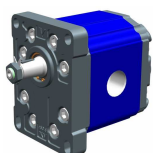

XM302

STANDARD EUROPEAN MOTOR
ø50.8 FLANGE - TAPER SHAFT

54

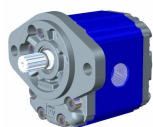

XM331

SAE B TYPE MOTOR
ø101.6 FLANGE - SPLINED SHAFT

56

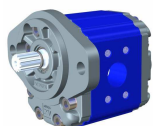

XM332

SAE B TYPE MOTOR
ø101.6 FLANGE - SPLINED SHAFT

58

APPENDIX - Special Versions

61

Max. Pressure Valves

62

Unions

63

Table of seals OR

65

Table of oil speeds

66

Table of Areas and Perimeters

67

Pressure conversion table

68

Conversion table

69

Table of oil viscosity according to temperature

70









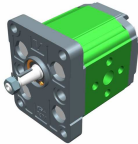
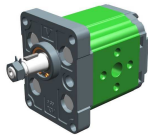

REVERSIBLE MOTORS

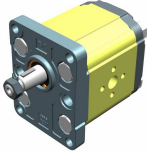

Index

Table of pressure drops	71
Table of Elements	72
Table of chemical resistance of elastomers	73
Table of mechanical features of elastomers	74
Table of tapping holes	75
Map	78

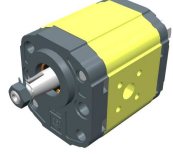
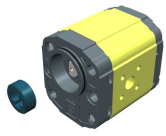
XV-0M		
		
References: XM-001	References: XM-012	References: XM-017
Standard Ø22 FLANGE	Ø22 BH FLANGE	Ø22 HY FLANGE

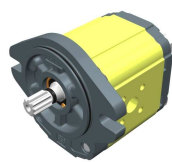
XV-1M		
		
References: XM-101	References: XM-113	References: XM-119
Ø25.4 FLANGE	Ø30 FLANGE	Ø32 BH FLANGE
		
References : XM-140	References: XM-161	References: XM-168
Ø32 HY FLANGE	Standard German Ø32 BH	Ø50.8 SAE AA FLANGE

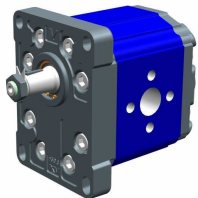
XV-2M		
		
References : XM-201	References : XM-210	References: XM-213
Ø36.5 FLANGE	Ø50 BH FLANGE	Ø50 HY FLANGE
		
References: XM-216	References : XM-217	References : XM-219
Standard German Ø52 BH FLANGE	Standard German Ø80 FLANGE	Ø82.5 SAE A FLANGE

XV-3M	
	
References : XM-301	References : XM-331
FLANGE Ø50,8 - Standard	FLANGE Ø101,6 SAE B

Vivoil Oleodinamica Vivolo s.r.l. presents a new series of gear reversible motors called XV-M. The quality of the product has been improved on by exploiting new and innovative solutions, both technical and constructive, for which the company has been **awarded 3 patents.**

The motors are divided into four groups:

The main features of the XV-0M are the following:

Displacements from 0.45 cm³ / revolution to 2.28 cm³/revolution.

Maximum pressures up to **280 bar**.

Versions w/ flanges: Ø22 – Standard;
Ø22 BH – Sagomata;
Ø22 HY – Sagomata.

Rotation speeds up to **9000 rpm**.

Configurations with inlet and outlet in the body, flange and cover.

Available shafts: Cylindrical with Woodruff key;

Milled shank;

Tapered 1:8 Woodruff key.

A version with internal drainage is also available.

The main features of the XV-1M are the following:

Displacements from 0.91 cm³ / revolution to 9.88 cm³/ revolution.

Maximum pressures up to **300 bar**.

Versions w/ flanges: Ø25.4 – Standard European;
Ø30 – Standard;
Ø32 BH – Body-Shaped;
Ø32 HY – Body-Shaped;
Ø32 BH – Standard German – Body-Shaped;
Ø50.8 – SAE AA

Rotation speeds up to **6000 rpm**

Configurations with inlet and outlet in the body, flange and cover.

Available shafts: Tapered 1:8 Woodruff key;

Parallel with key;

Milled shank;

Splined.

A version with internal drainage is also available.

The main features of the XV-2M are the following:

Displacements from 4.2 cm³ / revolution a 39.6 cm³/ revolution.

Maximum pressures up to **300 bar**.

Versions w/ flanges: Ø36,5 – Standard Europea;
Ø50 BH – Body-Shaped;
Ø50 HY – Body-Shaped;
Ø52 BH - Standard German – Body-Shaped;
Ø80 – Standard German;
Ø82,5 – SAE A.

Rotation speeds up to **3500 rpm**

Configurations with inlet and outlet in the body, flange and cover.

Available shafts: Tapered 1:8 Woodruff key;

Parallel with key;

Milled shank;

Splined.

A version with internal drainage is also available.

The main features of the XV-3M are the following:

Displacements from 14.89 cm³ / revolution to 86.87cm³/ revolution.

Maximum pressures up to **320 bar**.

Versions w/ flanges: Ø50,8 – Standard European;

Rotation speeds up to **3000 rpm**.

Available shafts: Tapered 1:8 Woodruff key;

Parallel with key;

Splined.

A version with internal drainage is also available.

Summary: Displacements - Torque - Power - Pressures - Speeds

	TYPE	Displacement	Torque	Power	Max Inlet Pressure	Max Drain Pressure	Min Starting Pressure	Min Speed	Max Speed
			1000 rev/min 100 bar						
XV-0M	XV-0M/0.45	0.45 cm ³ /rev	0,61 Nm	0,06 KW	280 bar	1 bar	25 bar	700 rev/min	9000 rev/min
	XV-0M/0.57	0.56 cm ³ /rev	0,76 Nm	0,08 KW	280 bar	1 bar	25 bar	700 rev/min	9000 rev/min
	XV-0M/0.76	0.75 cm ³ /rev	1,01 Nm	0,11 KW	280 bar	1 bar	25 bar	700 rev/min	9000 rev/min
	XV-0M/0.98	0.92 cm ³ /rev	1,24 Nm	0,13 KW	280 bar	1 bar	20 bar	700 rev/min	6000 rev/min
	XV-0M/1.27	1.26 cm ³ /rev	1,70 Nm	0,18 KW	280 bar	1 bar	15 bar	700 rev/min	6000 rev/min
	XV-0M/1.52	1.48 cm ³ /rev	2,00 Nm	0,21 KW	280 bar	1 bar	10 bar	700 rev/min	6000 rev/min
	XV-0M/2.30	2.28 cm ³ /rev	3,08 Nm	0,32 KW	210 bar	1 bar	10 bar	700 rev/min	5000 rev/min
XV-1M	XV-1M/0.9	0.91 cm ³ /rev	1,23 Nm	0,13 KW	280 bar	6 bar	30 bar	700 rev/min	6000 rev/min
	XV-1M/1.2	1.17 cm ³ /rev	1,58 Nm	0,17 KW	290 bar	6 bar	30 bar	700 rev/min	6000 rev/min
	XV-1M/1.7	1.56 cm ³ /rev	2,11 Nm	0,22 KW	290 bar	6 bar	30 bar	700 rev/min	6000 rev/min
	XV-1M/2.2	2.08 cm ³ /rev	2,81 Nm	0,29 KW	290 bar	6 bar	25 bar	700 rev/min	6000 rev/min
	XV-1M/2.6	2.60 cm ³ /rev	3,52 Nm	0,37 KW	300 bar	6 bar	20 bar	700 rev/min	6000 rev/min
	XV-1M/3.2	3.12 cm ³ /rev	4,22 Nm	0,44 KW	300 bar	6 bar	15 bar	700 rev/min	6000 rev/min
	XV-1M/3.8	3.64 cm ³ /rev	4,92 Nm	0,52 KW	300 bar	6 bar	15 bar	700 rev/min	6000 rev/min
	XV-1M/4.3	4.16 cm ³ /rev	5,63 Nm	0,59 KW	300 bar	6 bar	15 bar	700 rev/min	6000 rev/min
	XV-1M/4.9	4.94 cm ³ /rev	6,68 Nm	0,70 KW	300 bar	6 bar	15 bar	700 rev/min	6000 rev/min
	XV-1M/5.9	5.85 cm ³ /rev	7,91 Nm	0,83 KW	300 bar	6 bar	15 bar	700 rev/min	5000 rev/min
	XV-1M/6.5	6.50 cm ³ /rev	8,79 Nm	0,92 KW	300 bar	6 bar	10 bar	700 rev/min	5000 rev/min
	XV-1M/7.8	7.54 cm ³ /rev	10,20 Nm	1,07 KW	260 bar	6 bar	10 bar	700 rev/min	5000 rev/min
	XV-1M/9.8	9.88 cm ³ /rev	13,37 Nm	1,40 KW	230 bar	6 bar	10 bar	700 rev/min	4000 rev/min
	XV-2M	XV-2M/4	4.2 cm ³ /rev	5,68 Nm	0,60 KW	300 bar	6 bar	30 bar	700 rev/min
XV-2M/6		6.0 cm ³ /rev	8,12 Nm	0,85 KW	300 bar	6 bar	25 bar	700 rev/min	3500 rev/min
XV-2M/9		8.4 cm ³ /rev	11,36 Nm	1,19 KW	300 bar	6 bar	20 bar	700 rev/min	3500 rev/min
XV-2M/11		10.8 cm ³ /rev	14,61 Nm	1,53 KW	300 bar	6 bar	20 bar	700 rev/min	3500 rev/min
XV-2M/14		14.4 cm ³ /rev	19,48 Nm	2,04 KW	290 bar	6 bar	15 bar	700 rev/min	3500 rev/min
XV-2M/17		16.8 cm ³ /rev	22,73 Nm	2,38 KW	270 bar	6 bar	15 bar	700 rev/min	3500 rev/min
XV-2M/19		19.2 cm ³ /rev	25,97 Nm	2,72 KW	250 bar	6 bar	15 bar	700 rev/min	3000 rev/min
XV-2M/22		22.8 cm ³ /rev	30,84 Nm	3,23 KW	240 bar	6 bar	15 bar	700 rev/min	3000 rev/min
XV-2M/26		26.2 cm ³ /rev	35,44 Nm	3,71 KW	210 bar	6 bar	15 bar	700 rev/min	3000 rev/min
XV-2M/30		30.0 cm ³ /rev	40,58 Nm	4,25 KW	200 bar	6 bar	15 bar	700 rev/min	2500 rev/min
XV-2M/34		34.2 cm ³ /rev	46,27 Nm	4,85 KW	190 bar	6 bar	15 bar	700 rev/min	2500 rev/min
XV-3M	XV-3M/40	39.6 cm ³ /rev	53,57 Nm	5,61 KW	180 bar	6 bar	15 bar	700 rev/min	2000 rev/min
	XV-3M/15	14.89 cm ³ /rev	20,14 Nm	2,11 KW	320 bar	6 bar	20 bar	700 rev/min	3000 rev/min
	XV-3M/18	17.37 cm ³ /rev	23,50 Nm	2,46 KW	320 bar	6 bar	20 bar	700 rev/min	3000 rev/min
	XV-3M/21	21.10 cm ³ /rev	28,54 Nm	2,99 KW	300 bar	6 bar	15 bar	700 rev/min	3000 rev/min
	XV-3M/27	26.97 cm ³ /rev	36,49 Nm	3,82 KW	270 bar	6 bar	10 bar	700 rev/min	3000 rev/min
	XV-3M/32	32.27 cm ³ /rev	43,66 Nm	4,57 KW	270 bar	6 bar	10 bar	700 rev/min	3000 rev/min
	XV-3M/38	38.47 cm ³ /rev	52,04 Nm	5,45 KW	270 bar	6 bar	10 bar	700 rev/min	2800 rev/min
	XV-3M/43	43.44 cm ³ /rev	58,77 Nm	6,15 KW	250 bar	6 bar	10 bar	700 rev/min	2800 rev/min
	XV-3M/47	47.16 cm ³ /rev	63,80 Nm	6,68 KW	250 bar	6 bar	10 bar	700 rev/min	2800 rev/min
	XV-3M/51	50.88 cm ³ /rev	68,83 Nm	7,21 KW	250 bar	6 bar	10 bar	700 rev/min	2800 rev/min
	XV-3M/54	54.60 cm ³ /rev	73,86 Nm	7,74 KW	250 bar	6 bar	10 bar	700 rev/min	2300 rev/min
	XV-3M/61	60.81 cm ³ /rev	82,26 Nm	8,61 KW	220 bar	6 bar	10 bar	700 rev/min	2300 rev/min
	XV-3M/64	64.53 cm ³ /rev	87,30 Nm	9,14 KW	220 bar	6 bar	10 bar	700 rev/min	2300 rev/min
	XV-3M/70	70.74 cm ³ /rev	95,70 Nm	10,02 KW	210 bar	6 bar	10 bar	700 rev/min	2300 rev/min
	XV-3M/74	74.46 cm ³ /rev	100,73 Nm	10,55 KW	190 bar	6 bar	10 bar	700 rev/min	2300 rev/min
XV-3M/90	86.87 cm ³ /rev	117,52 Nm	12,31 KW	160 bar	6 bar	10 bar	700 rev/min	2300 rev/min	

General technical data

Type of fluid to be used	Mineral-based hydraulic oil HLP HV (D IN 51524)
Minimum operating viscosity	10 mm ² /s
Maximum operating viscosity	100 mm ² /s
Maximum admissible viscosity at start-up	1500 mm ² /s
Recommended viscosity	20 mm ² /s - 100 mm ² /s
Ambient temperature	-20 °C - 60°C
Fluid operating temperature	-15°C - 80°C
Recommended fluid operating temperature	30°C – 50° C
For temperatures above 120°C	Request FKM seals (V iton)
Max. outlet fluid pressure (OUT)	0.3 - 0.5 bars (with internal drainage)
Inlet fluid filtering (IN)	30 - 60 Microns
Outlet fluid filtering (OUT)	10 - 25 Microns
Max. inlet fluid speed (IN)	0.5 - 1.5 m/s
Max. outlet fluid speed (OUT)	3.0 - 5.5m/s

Flow rate tables

TYPE	cm3/rev	Flow rate l/min	rpm													Flow rate l/min			
			700	1000	1500	2000	2500	3000	3500	4000	4500	5000	5500	6000	7000		8000	9000	
XV 0M/0.45	0,45	Flow rate l/min	0,299	0,428	0,641	0,855	1,069	1,283	1,496	1,710	1,924	2,138	2,351	2,565	2,993	3,420	3,848	Flow rate l/min	
XV 0M/0.57	0,56		0,372	0,532	0,798	1,064	1,330	1,596	1,862	2,128	2,394	2,660	2,926	3,192	3,724	4,256	4,788		
XV 0M/0.76	0,75		0,499	0,713	1,069	1,425	1,781	2,138	2,494	2,850	3,206	3,563	3,919	4,275	4,988	5,700	6,413		
XV 0M/0.98	0,92		0,612	0,874	1,311	1,748	2,185	2,622	3,059	3,496	3,933	4,370	4,807	5,244					
XV 0M/1.27	1,26		0,838	1,197	1,796	2,394	2,993	3,591	4,190	4,788	5,387	5,985	6,584	7,182					
XV 0M/1.52	1,48		0,984	1,406	2,109	2,812	3,515	4,218	4,921	5,624	6,327	7,030	7,733	8,436					
XV 0M/2.30	2,28		1,516	2,166	3,249	4,332	5,415	6,498	7,581	8,664	9,747	10,830							

TYPE	cm3/rev	Flow rate l/min	rpm											Flow rate l/min	
			700	1000	1500	2000	2500	3000	3500	4000	4500	5000	5500		6000
XV 1M/0.9	0,91	Flow rate l/min	0,630	0,900	1,350	1,800	2,250	2,700	3,150	3,600	4,050	4,500	4,950	5,400	Flow rate l/min
XV 1M/1.2	1,17		0,840	1,200	1,800	2,400	3,000	3,600	4,200	4,800	5,400	6,000	6,600	7,200	
XV 1M/1.7	1,56		1,190	1,700	2,550	3,400	4,250	5,100	5,950	6,800	7,650	8,500	9,350	10,200	
XV 1M/2.2	2,08		1,540	2,200	3,300	4,400	5,500	6,600	7,700	8,800	9,900	11,000	12,100	13,200	
XV 1M/2.6	2,6		1,820	2,600	3,900	5,200	6,500	7,800	9,100	10,400	11,700	13,000	14,300	15,600	
XV 1M/3.2	3,12		2,240	3,200	4,800	6,400	8,000	9,600	11,200	12,800	14,400	16,000	17,600	19,200	
XV 1M/3.8	3,64		2,660	3,800	5,700	7,600	9,500	11,400	13,300	15,200	17,100	19,000	20,900	22,800	
XV 1M/4.3	4,16		3,010	4,300	6,450	8,600	10,750	12,900	15,050	17,200	19,350	21,500	23,650	25,800	
XV 1M/4.9	4,94		3,430	4,900	7,350	9,800	12,250	14,700	17,150	19,600	22,050	24,500	26,950	29,400	
XV 1M/5.9	5,85		4,130	5,900	8,850	11,800	14,750	17,700	20,650	23,600	26,550	29,500			
XV 1M/6.5	6,5		4,550	6,500	9,750	13,000	16,250	19,500	22,750	26,000	29,250	32,500			
XV 1M/7.8	7,54		5,460	7,800	11,700	15,600	19,500	23,400	27,300	31,200	35,100	39,000			
XV 1P/9.8	9,88		6,860	9,800	14,700	19,600	24,500	29,400	34,300	39,200					

TYPE	cm3/rev		rpm							
			700	1000	1500	2000	2500	3000		3500
XV 2M/4	4,2	Flow rate l/min	2,800	4,000	6,000	8,000	10,000	12,000	14,000	Flow rate l/min
XV 2M/6	6		4,200	6,000	9,000	12,000	15,000	18,000	21,000	
XV 2M/9	8,4		6,300	9,000	13,500	18,000	22,500	27,000	31,500	
XV 2M/11	10,8		7,700	11,000	16,500	22,000	27,500	33,000	38,500	
XV 2M/14	14,4		9,800	14,000	21,000	28,000	35,000	42,000	29,000	
XV 2M/17	16,8		11,900	17,000	25,500	34,000	42,500	51,000	59,500	
XV 2M/19	19,2		13,300	19,000	28,500	38,000	47,500	57,000		
XV 2M/22	22,8		15,400	22,000	33,000	44,000	55,000	66,000		
XV 2M/26	26,2		18,200	26,000	39,000	52,000	65,000	78,000		
XV 2M/30	30		21,000	30,000	45,000	60,000	75,000			
XV 2M/34	34,2		23,800	34,000	51,000	68,000	85,000			
XV 2M/40	39,6		28,000	40,000	60,000	80,000				

TYPE	cm3/rev		rpm							
			700	1000	1500	2000	2300	2500		3000
XV 3M/15	14,89	Flow rate l/min	9,90	14,15	21,22	28,29	32,54	35,37	42,44	Flow rate l/min
XV 3M/18	17,37		11,55	16,51	24,76	33,01	37,96	41,26	49,52	
XV 3M/21	21,10		14,03	20,04	30,06	40,08	46,10	50,11	60,13	
XV 3M/27	26,97		17,94	25,62	38,43	51,24	58,93	64,05	76,86	
XV 3M/32	32,27		21,46	30,65	45,98	61,31	70,50	76,63	91,96	
XV 3M/38	38,47		25,58	36,55	54,82	73,09	84,06	91,37		
XV 3M/43	43,44		28,88	41,26	61,89	82,53	94,91	103,16		
XV 3M/47	47,16		31,36	44,80	67,20	89,60	103,04	112,00		
XV 3M/51	50,88		33,84	48,34	72,51	96,67	111,17			
XV 3M/54	54,60		36,31	51,87	77,81	103,75	119,31			
XV 3M/61	60,81		40,44	57,77	86,65	115,54	132,87			
XV 3M/64	64,53		42,91	61,31	91,96	122,61	141,00			
XV 3M/70	70,74		47,04	67,20	100,80	134,40	154,56			
XV 3M/74	74,46		49,52	70,74	106,11	141,47	162,70			
XV 3M/90	86,87		57,77	82,53	123,79	165,05	189,81			

TORQUES ALLOWED ON SHAFT:

FORMULA FOR EVALUATING SHAFT	SHAFT [IDENTIFIER] - CODE - DESCRIPTION	T.2 [Nm]
$T.2 \leq \frac{v_i \times \Delta p \times \eta m}{20 \times \pi}$ <p>T.2 = max. torque allowed by shaft [Nm]</p>	XV-0M [A] - CI001 - Cilindrico ø 7 - M 7x1 - linguetta sp.2	2
	[B] - CF001 - Codolo fresato ø 7 - sp. 5	9,2
	[F] - CF005 - Codolo fresato ø 7 - sp.4,5 L = 9	8
	XV-1M [A] - CI001 - Parallel ø12 - M10x1 - key thk. 3	25,8
	[B] - CI002 - Parallel ø12.7 - key thk. 3.2 (SAE)	32,8
	[C] - CF001 - Milled shank ø10 - thk.5 ("BH" Standard German)	13,8
	[D] - CF002 - Milled shank ø10 - thk.5	13,8
	[E] - CF003 - Milled shank ø11 - thk.6.63 (SAE)	25,8
	[F] - CO001 - Tapered 1:8 - ø10 - M7x1 - key thk.2.4	43
	[G] - CO002 - Tapered 1:8 - ø14 - M10x1 - key thk.3	119,8
	[I] - CO004 - Tapered 1:8 - ø12.7 - 5/16" 24UNF-2A - key thk.3.2 (SAE)	90,4
	[J] - SCF04 - Splined ø11.7 - z=6, H=17.5, m=1.6, DIN 5482 12x9	22,6
	[K] - SCF05 - Splined ø12.344, z=9, H=19, SAE J498 9T 20/40DB	32,2
	[L] - SCF02 - Splined ø11.9, z=15, H=17.5, m=0.75	42,8
	[O] - CO002+HK - Tapered 1:8 - ø14 - M10x1, HK 14-12, key thk.3	119,8
	[P] - CI001+HK - Parallel ø12 - M10x1 with bearing HK 14-12 - key thk.3	25,8
	[Q] - SCF01 - Splined ø11.9, z=15, H=9, m=0.75	42,8
	[R] - SCF03 - Splined ø11.9, z=15, H=9, m=0.75	42,8
	XV-2M [A] - CI001 - Parallel ø15 - M6x1 - key thk.4	44.1
	[B] - CI002 - Parallel ø15.875 - 1/4"28-UNF key thk.4 (SAE A)	67.5
	[C] - CF001 - Miled shank ø15 - thk.8 ("BH" Standard German)	60.5
	[E] - CO001 - Tapered 1:8 - ø17,4 - M12x1,5 - key thk.4	233.2
	[F] - CO002 - Tapered 1:5 - ø17,4 - M12x1,5 - key thk.3	233.2
	[G] - SCF02 - Splined ø16,5 - z=9, H=13, m=1.6 DIN 5482 17x14	86.1
	[H] - SCF03 - Splined ø16.5 - z=9, H=18,8, m=1,6 DIN 5482 17x14	86.1
	[I] - SCF04 - Splined ø15.456 z=9, H=22.5, SAE J498 9T 16/32DP	67.1
	[K] - SCF05 - Splined ø16.5 z=9 H=8,1 m=1.6 DIN 5482 17x14	86.2
[L] - SCF01- Splined ø16.5 z=9 H=9,2 m=1.6 DIN 5482 17x14	86.2	
[M] - CO001 - Tapered 1:8 - ø17,4 - M12x1,5 - key thk.3,2	233.2	
XV-3M [A] - CO001 - Tapered 1:8 - ø22 - M14x1.5 - key thk.4	482	
[B] - CI001 - Parallel ø20 - M8 - key thk.5	181	
[C] - SCF03 - Splined ø21.5, z=13, H=25, m=1,6	223	
[H] - CI004 - Parallel ø22.225- 1/4"28-UNF key thk..6.35 (SAE B)	180	
[I] - SCF04 - Splined ø21.8059, z=13, H=25, SAE J498 9T 16/32DP	264	

NOTES:

For assemblies with a coupling, you should choose one as balanced as possible in order to reduce the vibrations and dynamic stresses to which the motor shaft may be subject.

Always make sure that the torque is less than or equal to the admissible torque of the shaft. Do not apply a direct axial or radial load on the motor shaft; if necessary, use suitable supports. Always use well-filtered oils containing no water or other emulsifying substance.

Never run the motor with oil and air solutions.

For motor with outlets on the flange, it is recommended not to exceed a flow rate of

4 l/min	XV-0M
20 l/min.	XV-1M
35 l/min	XV-2M

Useful calculation formulas

SYMBOL, UNIT OF MEASUREMENT, DESCRIPTION		
qv	l/min	Flow rate
vi	cm ³ /rev.	Displacement (volume of oil displaced per complete revolution of the shaft)
n	rpm	Shaft rotation speed
p1	bar	inlet pressure
p2	bar	outlet pressure
Δp	bar	Δp=p2 - p1 difference between outlet (OUT) and inlet (IN) pressure
Ph	kW	Hydraulic power delivered
Pm	kW	Mechanical power absorbed
T	Nm	Torque absorbed by shaft
ηv	-	0.91 – 0.96 volumetric efficiency (volumetric ratio between operation under load and loadless operation)
ηm	-	0.85 – 0.90 mechanical efficiency
ηt	-	ηt = ηv x ηm total efficiency

Basic Formulas	Derived Formulas	
$qv = \frac{vi \times n}{1000} \times \eta v$	$vi = \frac{qv \times 1000}{n \times \eta v}$	$n = \frac{qv \times 1000}{vi \times \eta v}$
$T = \frac{vi \times \Delta p \times \eta m}{20 \times \pi}$	$vi = \frac{T \times 20 \times \pi}{\Delta p \times \eta m}$	$\Delta p = \frac{T \times 20 \times \pi}{vi \times \eta m}$
$Ph = \frac{qv \times \Delta p}{600}$	$qv = \frac{Ph \times 600}{\Delta p}$	$\Delta p = \frac{Ph \times 600}{qv}$
$Pm = \frac{vi \times \Delta p \times n \times \eta m}{600000}$	$vi = \frac{Pm \times 600000}{\Delta p \times n \times \eta m}$	$\Delta p = \frac{600000 \times \eta m}{vi \times n \times \eta m}$

Constructive features

PART	MATERIAL	MECHANICAL FEATURES
MOTOR BODY	Extruded alloy Series 7000, heat treated and anodised	Rp = 345 N/mm ² (Yield strength) Rm = 382 N/mm ² (Breaking strength)
FLANGE AND COVER	Die-cast aluminium alloy with excellent mechanical features, heat treated and anodised	Rp = 310÷350 N/mm ² (Yield strength) Rm = 350÷400 N/mm ² (Breaking strength)
GEAR BUSH BEARINGS	Special heat-treated tin alloy with excellent mechanical features and high anti-friction capacity. Self-lubricating bushes DU	Rp = 350 N/mm ² (Yield strength) Rm = 390 N/mm ² (Breaking strength)
GEARS	Steel UNI 7846	Rs = 980 N/mm ² (Yield strength) Rm = 1270÷1570 N/mm ² (Breaking strength)
SEALS	A 727 Standard Acrylonitrile F 975 Viton FKM	70 Shore, thermal resistance 120°C 80 Shore, thermal resistance 200°C
BACK-UP RINGS	Virgin PTFE Tecnil Q3	

XV-0M CHARACTERISTIC FLOW RATE CURVES

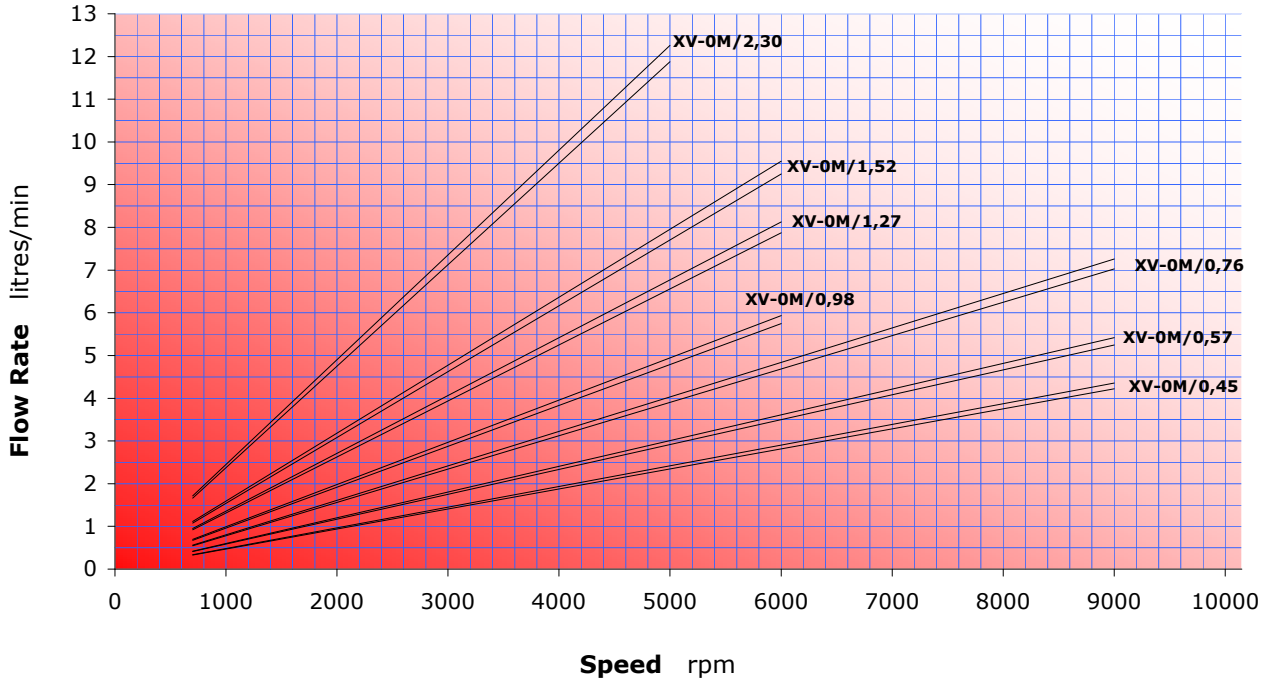

XV-0M MOTOR TORQUE

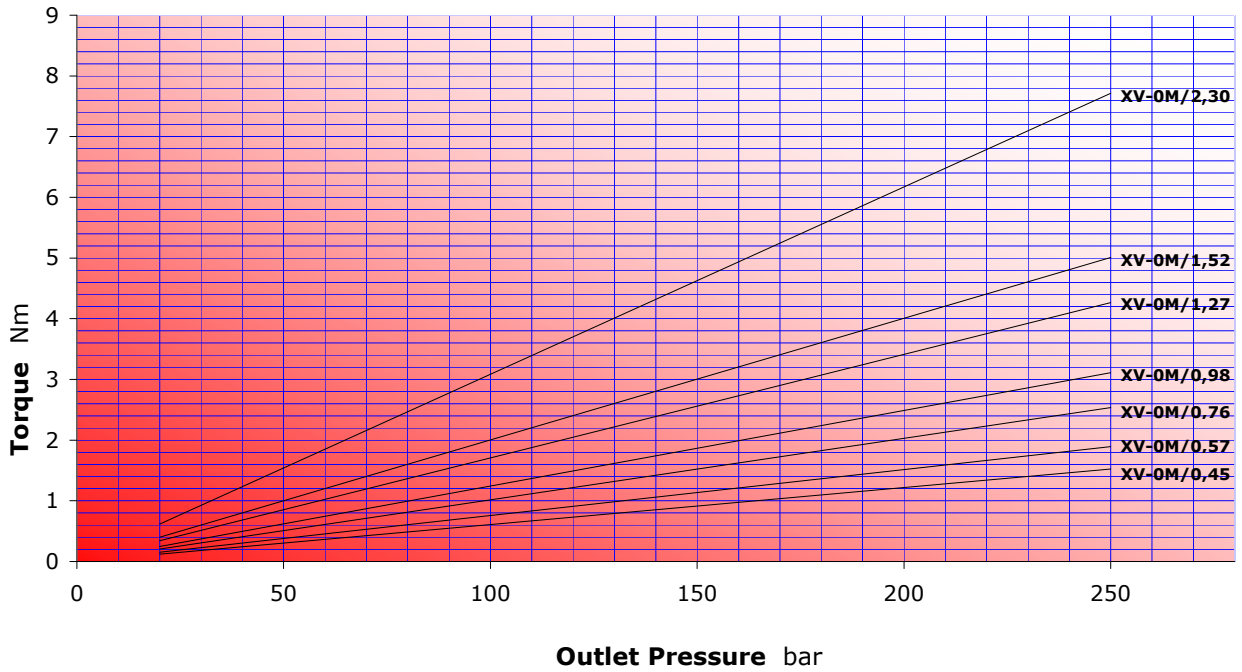

XV-1M CHARACTERISTIC FLOW RATE CURVES

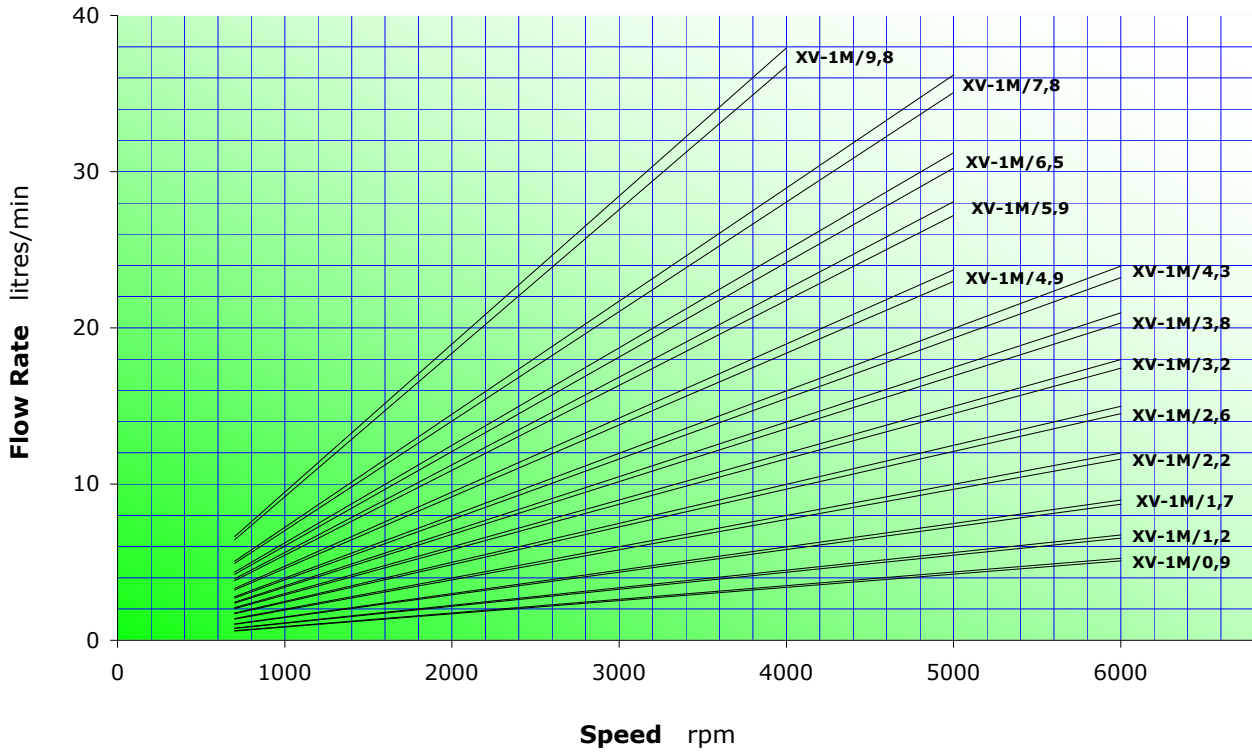

XV-1M MOTOR TORQUE

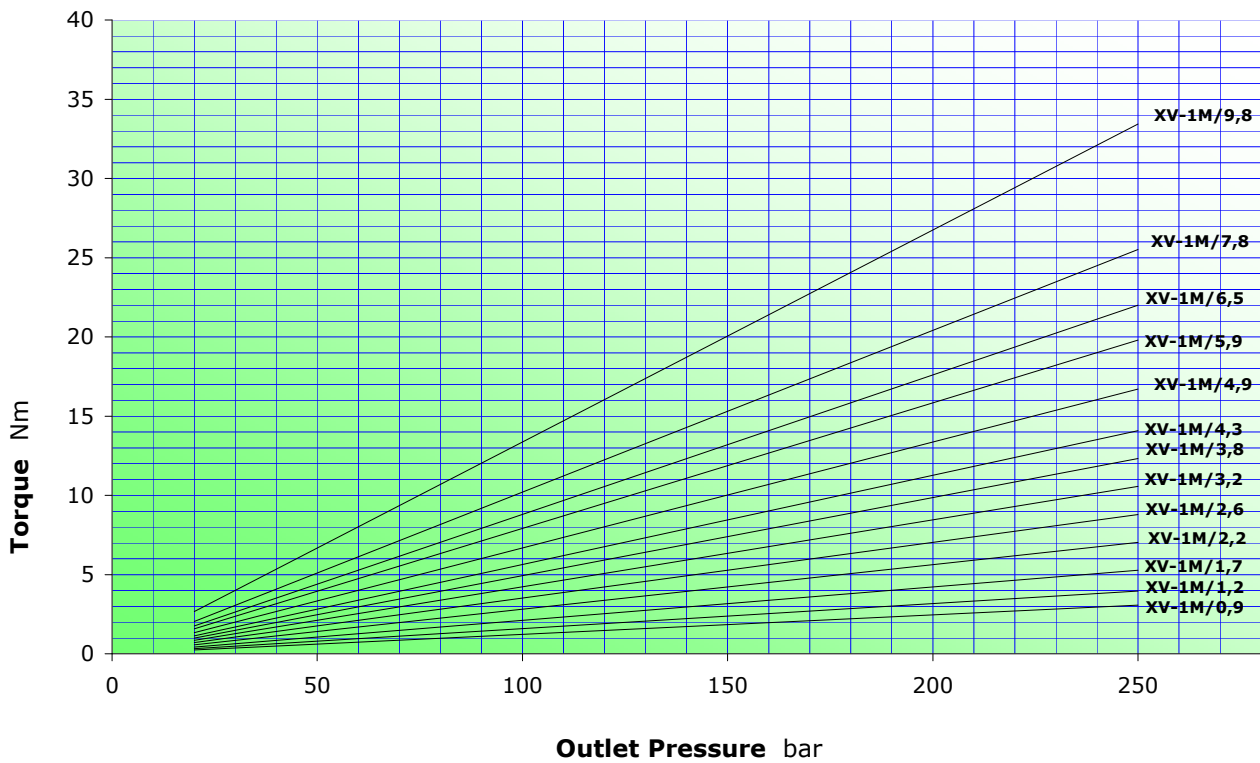

XV-2M CHARACTERISTIC FLOW RATE CURVES

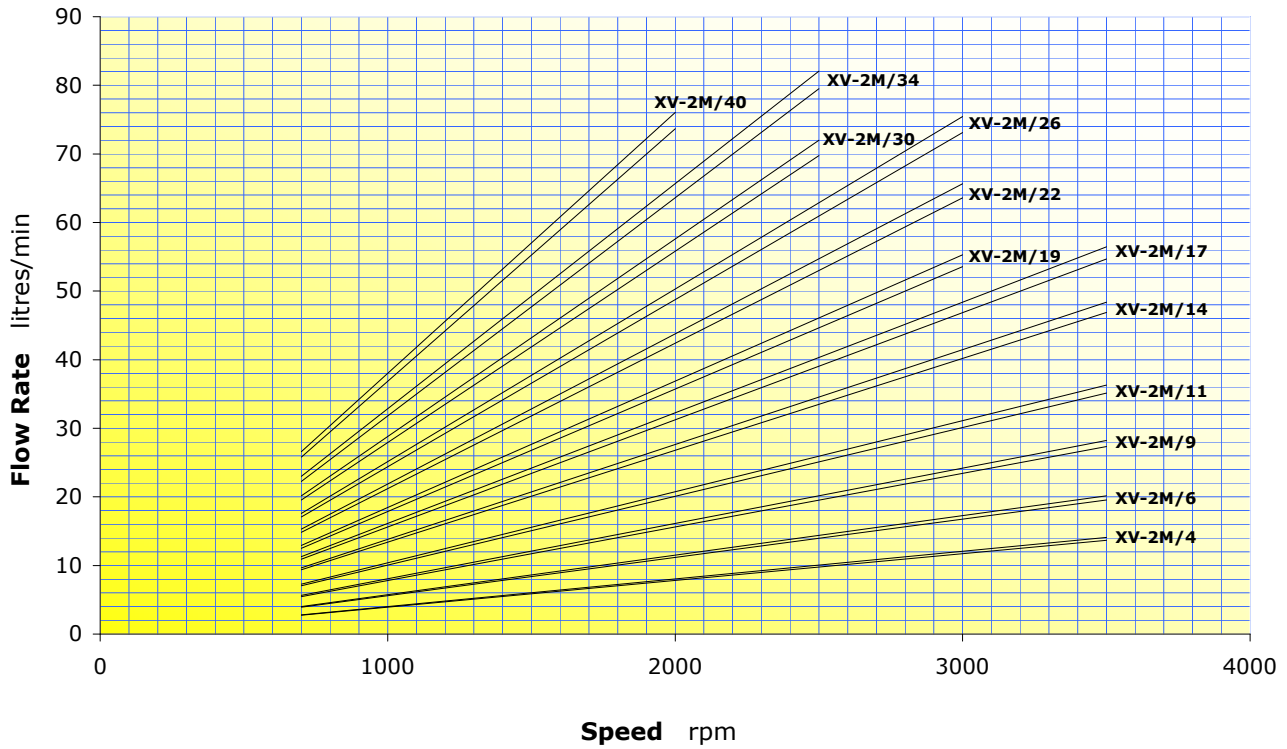

XV-2M MOTOR TORQUE

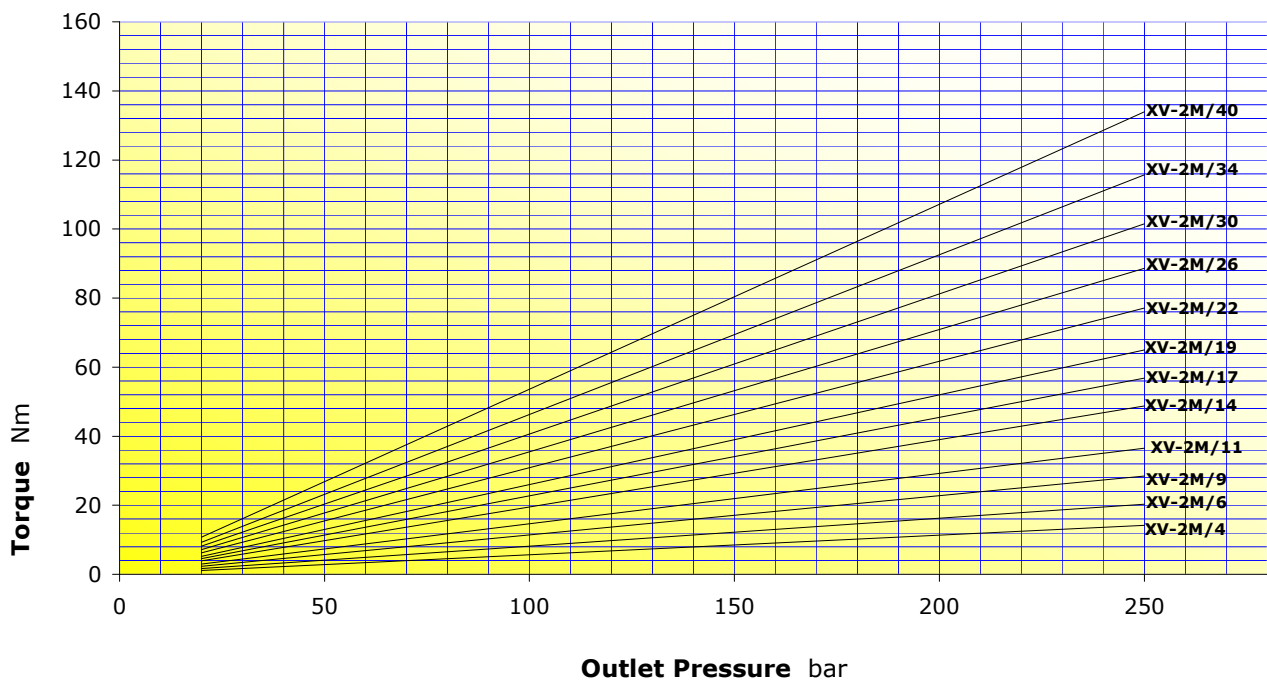

XV-3M CHARACTERISTIC FLOW RATE CURVES

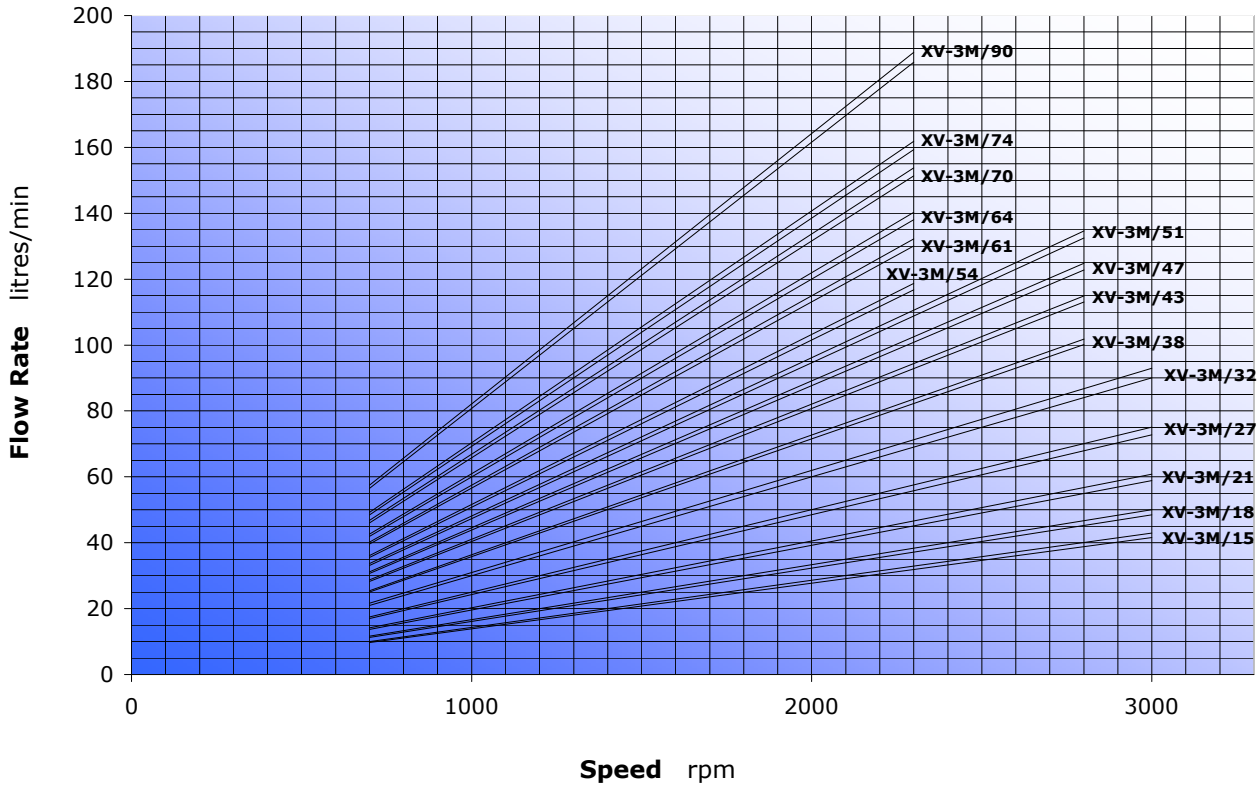

XV-3M MOTOR TORQUE

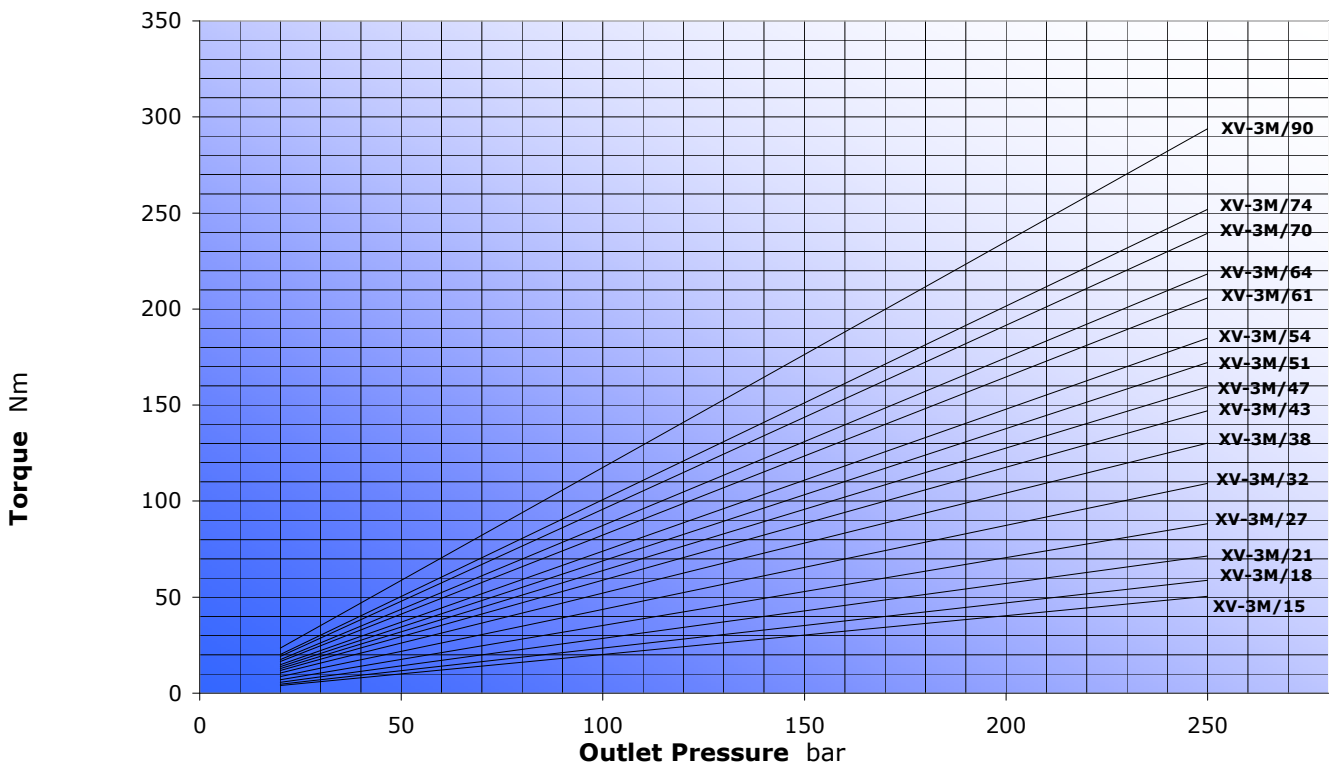

reversible motor - series XV

XV-OM

STANDARD MOTOR
Ø22 FLANGE - PARALLEL SHAFT

X 0 M 06 01 A B B E

Series	X	series XV
Group	0	group 0
Category	M	reversible motor
Displacement	06	0.76
Flange	01	Ø22 reversible rotation
Shaft	A	CI001 - Parallel ø7 - M7x1 - key thk. 2
Body	IN	inlet - 1/4" GAS
	OUT	outlet - 1/4" GAS
Cover	E	reversible w/external drainage

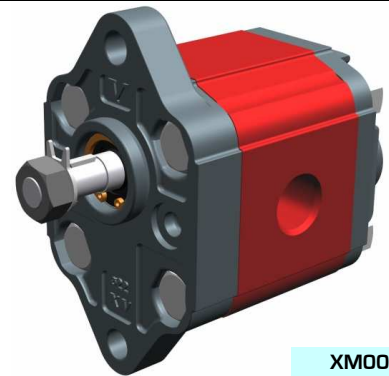

XM001

Technical data table

TYPE	Displacement cm3/rev	Max. Pressure		CODE																	
		P1 bar	P3 bar	External drainage		Internal drainage															
XV-OM/0.45	0,45	220	280	X	0	M	04	01	A	B	B	E	X	0	M	04	01	A	B	B	F
XV-OM/0.57	0,56	220	280	X	0	M	05	01	A	B	B	E	X	0	M	05	01	A	B	B	F
XV-OM/0.76	0,75	220	280	X	0	M	06	01	A	B	B	E	X	0	M	06	01	A	B	B	F
XV-OM/0.98	0,92	220	280	X	0	M	07	01	A	B	B	E	X	0	M	07	01	A	B	B	F
XV-OM/1.27	1,26	220	280	X	0	M	09	01	A	B	B	E	X	0	M	09	01	A	B	B	F
XV-OM/1.52	1,48	220	280	X	0	M	11	01	A	B	B	E	X	0	M	11	01	A	B	B	F
XV-OM/2.30	2,28	190	210	X	0	M	13	01	A	B	B	E	X	0	M	13	01	A	B	B	F

P1) Max. working pressure - P3) Max. peak pressure

For heavy-duty applications, it is recommended to check the admissible torque of the shaft

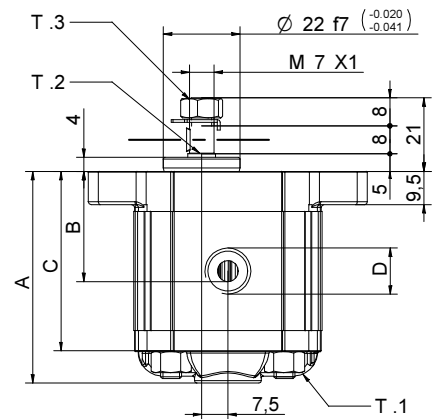
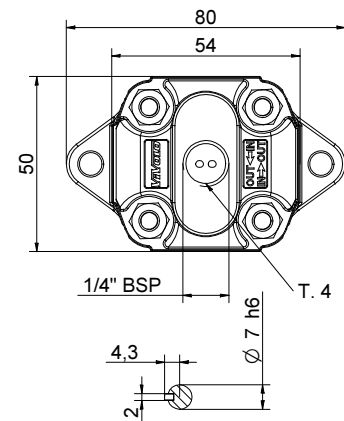

Dimensions table

TYPE	Weight kg	A	B	C	D	D
		mm	mm	mm	IN	OUT
XV-OM/0.45	0,420	58,0	27,3	49,0	1/4" BSPP	1/4" BSPP
XV-OM/0.57	0,430	59,0	27,8	50,0	1/4" BSPP	1/4" BSPP
XV-OM/0.76	0,440	60,5	28,5	51,5	1/4" BSPP	1/4" BSPP
XV-OM/0.98	0,460	62,0	29,3	53,0	1/4" BSPP	1/4" BSPP
XV-OM/1.27	0,480	64,5	30,5	55,5	1/4" BSPP	1/4" BSPP
XV-OM/1.52	0,500	66,5	31,5	57,5	1/4" BSPP	1/4" BSPP
XV-OM/2.30	0,560	72,5	34,5	63,5	1/4" BSPP	1/4" BSPP

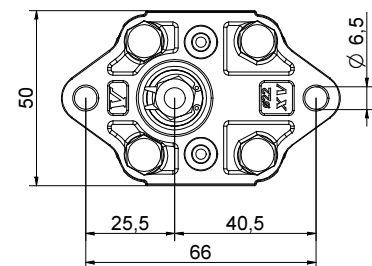

26/08/04 X0R0601ABBE.dft

T.1 = 11.7÷13.7 [Nm] - screw tightening torque M6

T.3 = 11.5 [Nm] - torque wrench setting 11

T.2 = 2.1 [Nm] - admissible shaft torque (N.B. When choosing a shaft, always check the admissible torque).

Table of variations

XV-OM

Standard ø22 FLANGE

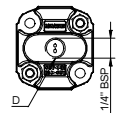
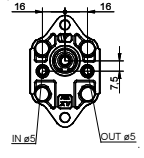
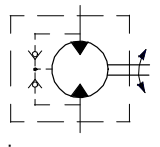
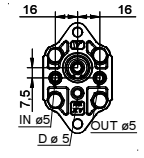
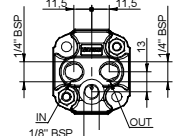
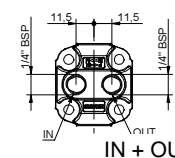
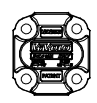
Standard ø22 FLANGE		Shaft		Cover			
	01	CI001 - Parallel T.2 = 2.1 [Nm]	A	CF001 - Milled shank T.2 = 9.2 [Nm]	B	 External drainage	E
	04	CF005 - Milled shank T.2 = 8.4 [Nm]	F	CO001 - Tapered T.2 = 21.9 [Nm]	E	 Internal drainage	F
	05					 IN + OUT + external	K
						 IN + OUT + internal	L
						 Flange drainage	P

Displacement	
TYPE	CODE
XV-OM/0.45	04
XV-OM/0.57	05
XV-OM/0.76	06
XV-OM/0.98	07
XV-OM/1.27	09
XV-OM/1.52	11
XV-OM/2.30	13

Standard bodies		
Displacement cm3/rev	Standard threads	
	0.17	B - B
0.25	B - B	Z - Z
0.45	B - B	Z - Z
0.57	B - B	Z - Z
0.76	B - B	Z - Z
0.98	B - B	Z - Z
1.27	B - B	Z - Z
1.52	B - B	Z - Z
2.30	B - B	Z - Z

Table showing standard flange and thread combinations available in stock

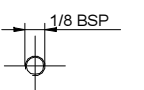
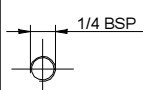
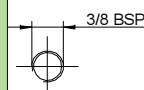
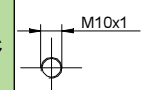
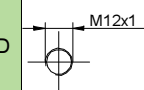
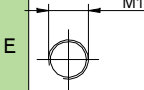
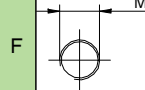
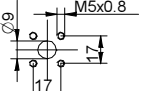
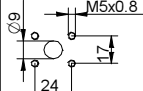
Body (threads/flanges)													
	A		B		C		D		E		F		G
	H		I	Closed Body		Z							

reversible motor - series XV

XV-OM

BH TYPE MOTOR
ø22 BODY-SHAPED FLANGE - MILLED SHANK

X 0 M 06 07 B B B E

Series	X	series XV
Group	0	group 0
Category	M	reversible motor
Displacement	06	0.76
Flange	07	Ø22 BH reversible rotation
Shaft	B	CF001 - Milled shank ø7 - thk.5
Body	IN	inlet - 1/4" GAS
	OUT	outlet - 1/4" GAS
Cover	E	reversible w/external drainage



XM012

Technical data table

TYPE	Displacement cm3/rev	Max. Pressure		CODE	
		P1 bar	P3 bar	External drainage	Internal drainage
XV-OM/0.45	0,45	220	280	X 0 M 04 07 B B B E	X 0 M 04 07 B B B F
XV-OM/0.57	0,56	220	280	X 0 M 05 07 B B B E	X 0 M 05 07 B B B F
XV-OM/0.76	0,75	220	280	X 0 M 06 07 B B B E	X 0 M 06 07 B B B F
XV-OM/0.98	0,92	220	280	X 0 M 07 07 B B B E	X 0 M 07 07 B B B F
XV-OM/1.27	1,26	220	280	X 0 M 09 07 B B B E	X 0 M 09 07 B B B F
XV-OM/1.52	1,48	220	280	X 0 M 11 07 B B B E	X 0 M 11 07 B B B F
XV-OM/2.30	2,28	190	210	X 0 M 13 07 B B B E	X 0 M 13 07 B B B F

P1) Max. working pressure - P3) Max. peak pressure

For heavy-duty applications, it is recommended to check the admissible torque of the shaft

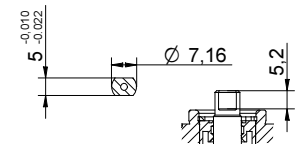
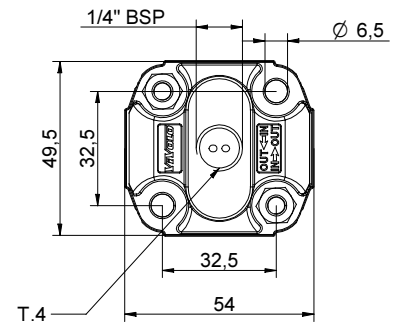

Dimensions table

TYPE	Weight kg	A	B	C	D	D
		mm	mm	mm	IN	OUT
XV-OM/0.45	0,420	58,0	27,3	49,0	1/4" BSPP	1/4" BSPP
XV-OM/0.57	0,430	59,0	27,8	50,0	1/4" BSPP	1/4" BSPP
XV-OM/0.76	0,440	60,5	28,5	51,5	1/4" BSPP	1/4" BSPP
XV-OM/0.98	0,460	62,0	29,3	53,0	1/4" BSPP	1/4" BSPP
XV-OM/1.27	0,480	64,5	30,5	55,5	1/4" BSPP	1/4" BSPP
XV-OM/1.52	0,500	66,5	31,5	57,5	1/4" BSPP	1/4" BSPP
XV-OM/2.30	0,560	72,5	34,5	63,5	1/4" BSPP	1/4" BSPP

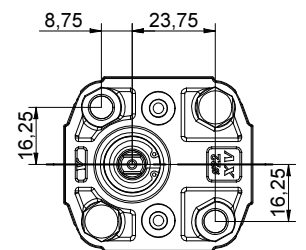
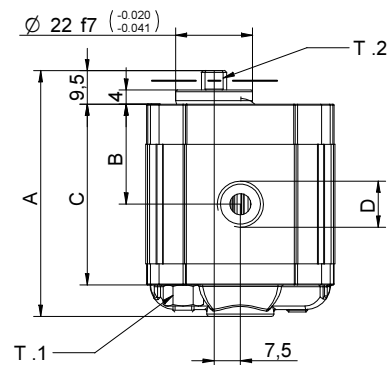

26/08/04 X0R0607888E.dft





T.1 = 11.7÷13.7 [Nm] - screw tightening torque M6

T.2 = 9.2 [Nm] - admissible shaft torque (N.B. When choosing a shaft, always check the admissible torque).

Table of variations

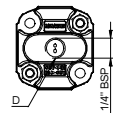
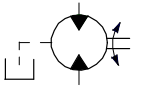
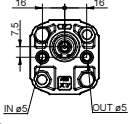
XV-OM

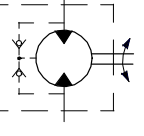
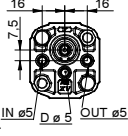
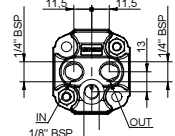
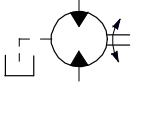
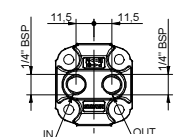
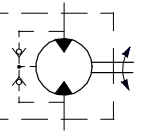
ø22 "BH" Body-Shaped FLANGE

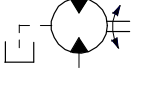
ø22 "BH" Body-Shaped FLANGE		Shaft		Cover			
	07	CI001 - Parallel T.2 = 2.1 [Nm]	A	CF001 - Milled shank T.2 = 9.2 [Nm]	B	  External drainage	E
	10	CF005 - Milled shank T.2 = 8.4 [Nm]	F	CO001 - Tapered T.2 = 21.9 [Nm]	E	  Internal drainage	F
	11					  IN + OUT + external	K
						  IN + OUT + internal	L
						  Flange drainage	P

Displacement	
TYPE	CODE
XV-OM/0.45	04
XV-OM/0.57	05
XV-OM/0.76	06
XV-OM/0.98	07
XV-OM/1.27	09
XV-OM/1.52	11
XV-OM/2.30	13

Standard bodies		
Displacement cm ³ /rev	Standard threads	
	0.17	B - B
0.25	B - B	Z - Z
0.45	B - B	Z - Z
0.57	B - B	Z - Z
0.76	B - B	Z - Z
0.98	B - B	Z - Z
1.27	B - B	Z - Z
1.52	B - B	Z - Z
2.30	B - B	Z - Z

Table showing standard flange and thread combinations available in stock

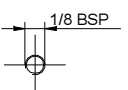
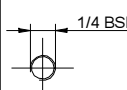
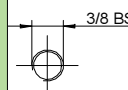
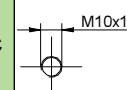
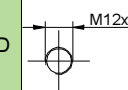
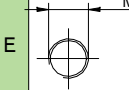
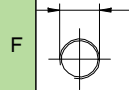
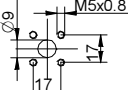
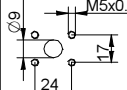
Body (threads/flanges)													
	A		B		C		D		E		F		G
	H		I	Closed Body		Z							

reversible motor - series XV

XV-OM

HY TYPE MOTOR
 ø22 BODY-SHAPED FLANGE - MILLED SHANK

X 0 M 06 21 B B B E

Series	X	series XV
Group	0	group 0
Category	M	reversible motor
Displacement	06	0.76
Flange	21	Ø22 HY reversible rotation
Shaft	B	CF001 - Milled shank ø7 - thk.5
Body	IN	inlet - 1/4" GAS
	OUT	outlet - 1/4" GAS
Cover	E	reversible w/external drainage



XM017

Technical data table						
TYPE	Displacement cm3/rev	Max. Pressure		CODE		
		P1 bar	P3 bar	External drainage		Internal drainage
XV-OM/0.45	0,45	220	280	X 0 M 04 21 B B B E	X 0 M 04 21 B B B F	
XV-OM/0.57	0,56	220	280	X 0 M 05 21 B B B E	X 0 M 05 21 B B B F	
XV-OM/0.76	0,75	220	280	X 0 M 06 21 B B B E	X 0 M 06 21 B B B F	
XV-OM/0.98	0,92	220	280	X 0 M 07 21 B B B E	X 0 M 07 21 B B B F	
XV-OM/1.27	1,26	220	280	X 0 M 09 21 B B B E	X 0 M 09 21 B B B F	
XV-OM/1.52	1,48	220	280	X 0 M 11 21 B B B E	X 0 M 11 21 B B B F	
XV-OM/2.30	2,28	190	210	X 0 M 13 21 B B B E	X 0 M 13 21 B B B F	

P1) Max. working pressure - P3) Max. peak pressure

For heavy-duty applications, it is recommended to check the admissible torque of the shaft

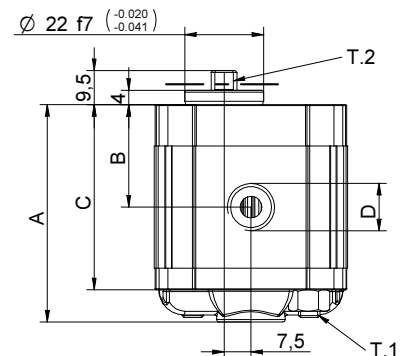
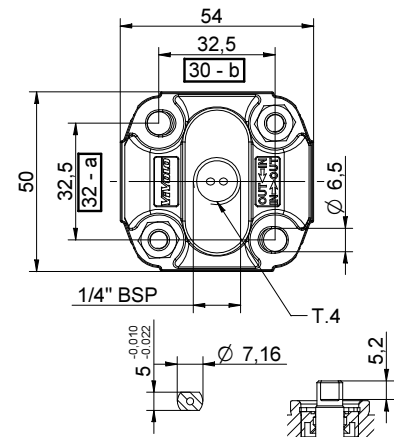

Dimensions table						
TYPE	Weight kg	A	B	C	D	D
		mm	mm	mm	IN	OUT
XV-OM/0.45	0,420	58,0	27,3	49,0	1/4" BSPP	1/4" BSPP
XV-OM/0.57	0,430	59,0	27,8	50,0	1/4" BSPP	1/4" BSPP
XV-OM/0.76	0,440	60,5	28,5	51,5	1/4" BSPP	1/4" BSPP
XV-OM/0.98	0,460	62,0	29,3	53,0	1/4" BSPP	1/4" BSPP
XV-OM/1.27	0,480	64,5	30,5	55,5	1/4" BSPP	1/4" BSPP
XV-OM/1.52	0,500	66,5	31,5	57,5	1/4" BSPP	1/4" BSPP
XV-OM/2.30	0,560	72,5	34,5	63,5	1/4" BSPP	1/4" BSPP

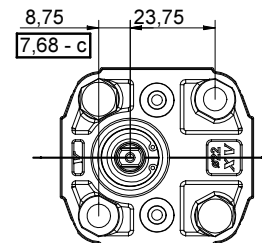

26/08/04 XOR0621888E.dft

T.1 = 11.7÷13.7 [Nm] - screw tightening torque M6





T.2 = 9.2 [Nm] - admissible shaft torque (N.B. When choosing a shaft, always check the admissible torque).

NOTE: This type of pump is also interchangeable with distance between centres of fastening in M5 (see dim. a, b, c).

Table of variations

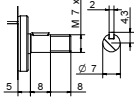
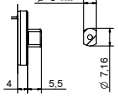
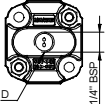
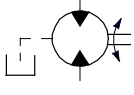
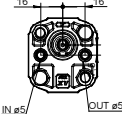
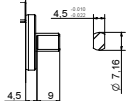
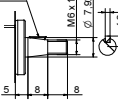
XV-OM

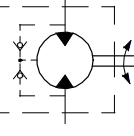
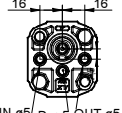
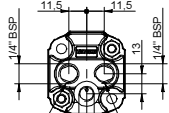
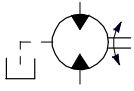
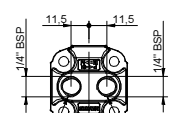
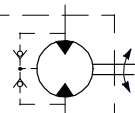
ø22 "HY" Body-Shaped FLANGE

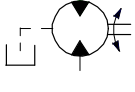
ø22 "HY" Body-Shaped FLANGE		Shaft		Cover			
	21	CI001 - Parallel T.2 = 2.1 [Nm] 	A	CF001 - Milled shank T.2 = 9.2 [Nm] 	B	 External drainage 	E
	24	CF005 - Milled shank T.2 = 8.4 [Nm] 	F	CO001 - Tapered T.2 = 21.9 [Nm] 	E	 Internal drainage 	F
	25					 IN + OUT + external 	K
						 IN + OUT + internal 	L
						 Flange drainage 	P

Displacement	
TYPE	CODE
XV-OM/0.45	04
XV-OM/0.57	05
XV-OM/0.76	06
XV-OM/0.98	07
XV-OM/1.27	09
XV-OM/1.52	11
XV-OM/2.30	13

Standard bodies		
Displacement cm ³ /rev	Standard threads	
	0.17	B - B
0.25	B - B	Z - Z
0.45	B - B	Z - Z
0.57	B - B	Z - Z
0.76	B - B	Z - Z
0.98	B - B	Z - Z
1.27	B - B	Z - Z
1.52	B - B	Z - Z
2.30	B - B	Z - Z

Table showing standard flange and thread combinations available in stock

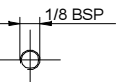
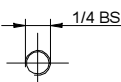
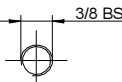
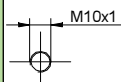
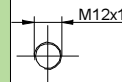
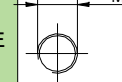
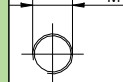
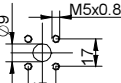
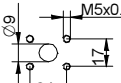
Body (threads/flanges)													
	A		B		C		D		E		F		G
	H		I	Closed Body		Z							

reversible motor - series XV

STANDARD EUROPEAN MOTOR
 ø25.4 FLANGE - TAPER SHAFT

XV-1M

X 1 M 25 01 F I I E

Series	X	series XV
Group	1	group 1
Category	M	reversible motor
Displacement	25	3.8
Flange	01	Ø25.4 STANDARD EUROPEAN reversible rotation
Shaft	F	CO001 - Tapered 1:8 - ø10 - M7x1 - key thk.2.4
Body	IN	inlet - Ø30 Ø12 M6
	OUT	outlet - Ø30 Ø12 M6
Cover	E	with drainage 1/4" BSP

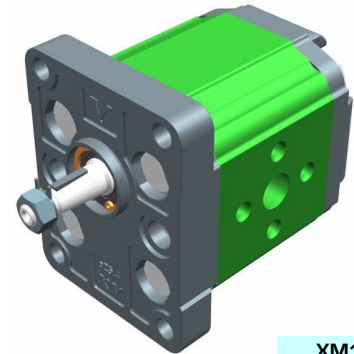

XM101

Technical data table

TYPE	Displacement cm3/rev	Max. Pressure		CODE	
		P1 bar	P3 bar	External drainage	Internal drainage
XV-1M/0.9	0,91	240	280	X 1 M 16 01 F I I E	X 1 M 16 01 F I I F
XV-1M/1.2	1,17	250	290	X 1 M 17 01 F I I E	X 1 M 17 01 F I I F
XV-1M/1.7	1,56	250	290	X 1 M 18 01 F I I E	X 1 M 18 01 F I I F
XV-1M/2.2	2,08	250	290	X 1 M 20 01 F I I E	X 1 M 20 01 F I I F
XV-1M/2.6	2,60	250	300	X 1 M 21 01 F I I E	X 1 M 21 01 F I I F
XV-1M/3.2	3,12	250	300	X 1 M 23 01 F I I E	X 1 M 23 01 F I I F
XV-1M/3.8	3,64	250	300	X 1 M 25 01 F I I E	X 1 M 25 01 F I I F
XV-1M/4.3	4,16	250	300	X 1 M 27 01 F I I E	X 1 M 27 01 F I I F
XV-1M/4.9	4,94	250	300	X 1 M 29 01 F I I E	X 1 M 29 01 F I I F
XV-1M/5.9	5,85	250	300	X 1 M 31 01 F I I E	X 1 M 31 01 F I I F
XV-1M/6.5	6,50	250	300	X 1 M 32 01 F I I E	X 1 M 32 01 F I I F
XV-1M/7.8	7,54	220	260	X 1 M 34 01 F I I E	X 1 M 34 01 F I I F
XV-1M/9.8	9,88	190	230	X 1 M 36 01 F I I E	X 1 M 36 01 F I I F

P1) Max. working pressure - P3) Max. peak pressure

For heavy-duty applications, it is recommended to check the admissible torque of the shaft

Dimensions table

TYPE	Weight kg	A	B	C	D	E	F	D	E	F
		mm	mm	mm	IN	IN	IN	OUT	OUT	OUT
XV-1M/0.9	0,950	78,1	37,3	66,1	ø12	30	M6x1	ø12	30	M6x1
XV-1M/1.2	0,970	79,0	37,8	67,0	ø12	30	M6x1	ø12	30	M6x1
XV-1M/1.7	1,010	80,5	38,5	68,5	ø12	30	M6x1	ø12	30	M6x1
XV-1M/2.2	1,030	82,5	39,5	70,5	ø12	30	M6x1	ø12	30	M6x1
XV-1M/2.6	1,060	84,5	40,5	72,5	ø12	30	M6x1	ø12	30	M6x1
XV-1M/3.2	1,090	86,5	41,5	74,5	ø12	30	M6x1	ø12	30	M6x1
XV-1M/3.8	1,120	88,5	42,5	76,5	ø12	30	M6x1	ø12	30	M6x1
XV-1M/4.3	1,170	90,5	43,5	78,5	ø12	30	M6x1	ø12	30	M6x1
XV-1M/4.9	1,200	93,5	45,0	81,5	ø12	30	M6x1	ø12	30	M6x1
XV-1M/5.9	1,260	97,0	46,8	85,0	ø12	30	M6x1	ø12	30	M6x1
XV-1M/6.5	1,300	98,5	48,0	86,5	ø12	30	M6x1	ø12	30	M6x1
XV-1M/7.8	1,360	103,5	50,0	91,5	ø12	30	M6x1	ø12	30	M6x1
XV-1M/9.8	1,500	112,5	54,5	100,5	ø12	30	M6x1	ø12	30	M6x1

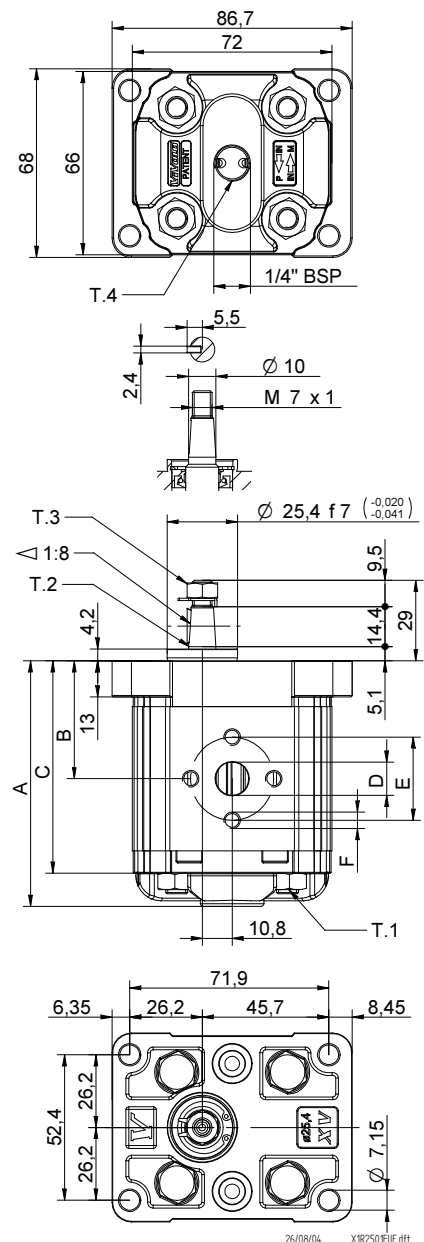

T.1 = 24.5÷29.4 [Nm] - screw tightening torque M8

T.3 = 11.5 [Nm] - torque wrench setting 11

T.2 = 43 [Nm] - admissible shaft torque (N.B. When choosing a shaft, always check the admissible torque).

T.4 = 0.3÷0.5 bar - max. drainage pressure

Table of variations

XV-1M

ø25.4 FLANGE

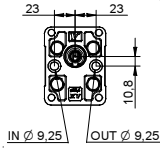
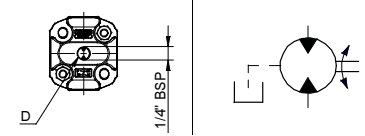
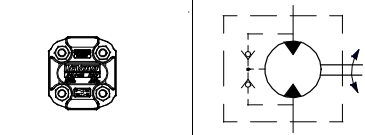
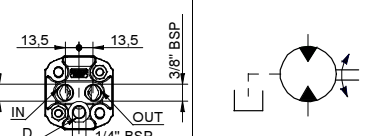
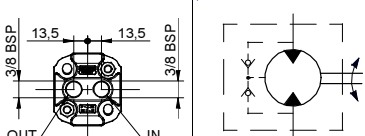
ø25.4 FLANGE		Shaft				Cover	
	01	CO001 - Tapered T.2 = 43 [Nm]	F	CF002 - Milled shank T.2 = 13.8 [Nm]	D	 External drainage	E
	04	SCF04 - Splined T.2 = 22.6 [Nm] m=1,6 Z=6 DIN 5482 - 12x9	J	SCF02 - Splined T.2 = 42.8 [Nm] m=0,75 Z=15	L		 Internal drainage
SCF01 - Splined T.2 = 42.8 [Nm] m=0,75 Z=15		Q	SCF03 - Splined T.2 = 42.8 [Nm] m=0,75 Z=15	R	 IN + OUT + external	K	
 IN + OUT + internal		L					

Displacement	
TYPE	CODE
XV-1M/0.9	16
XV-1M/1.2	17
XV-1M/1.7	18
XV-1M/2.2	20
XV-1M/2.6	21
XV-1M/3.2	23
XV-1M/3.8	25
XV-1M/4.3	27
XV-1M/4.9	29
XV-1M/5.9	31
XV-1M/6.5	32
XV-1M/7.8	34
XV-1M/9.8	36

Standard bodies					
Displacement cm3/rev	Standard threads				
	0.9	I - I	B - B	J - J	Z - Z
1.2	I - I	B - B	J - J	Z - Z	
1.7	I - I	B - B	J - J	Z - Z	
2.2	I - I	B - B	J - J	Z - Z	
2.6	I - I	B - B	J - J	Z - Z	
3.2	I - I	B - B	J - J	Z - Z	
3.8	I - I	B - B	J - J	Z - Z	
4.3	I - I	B - B	J - J	Z - Z	
4.9	I - I	B - B	J - J	Z - Z	
5.9	I - I	B - B	J - J	Z - Z	
6.5	I - I	B - B	J - J	Z - Z	
7.8	I - I	B - B	J - J	Z - Z	
9.8	I - I	B - B	J - J	Z - Z	

Table showing standard flange and thread combinations available in stock

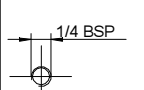
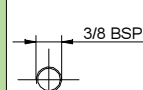
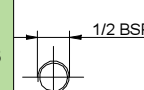
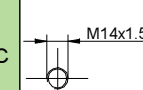
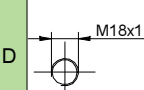
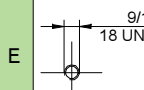
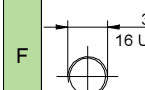
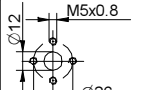
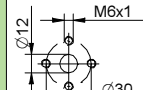
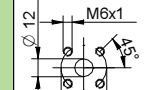
Body (threads/flanges)						
 A	 B	 C	 D	 E	 F	 G
 H	 I	 J	Closed Body Z			

reversible motor - series XV

STANDARD EUROPEAN MOTOR
 ø25.4 FLANGE - TAPER SHAFT

XV-1M

X 1 M 25 01 F B B E

Series	X	series XV
Group	1	group 1
Category	M	reversible motor
Displacement	25	3.8
Flange	01	Ø25.4 STANDARD EUROPEAN reversible rotation
Shaft	F	CO001 - Tapered 1:8 - ø10 - M7x1 - key thk.2.4
Body	IN	inlet - 3/8" GAS
	OUT	outlet - 3/8" GAS
Cover	E	with drainage 1/4" BSP

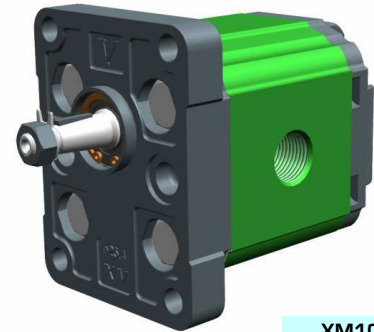

XM105

Technical data table

TYPE	Displacement cm3/rev	Max. Pressure		CODE													
		P1 bar	P3 bar	External drainage		Internal drainage											
XV-1M/0.9	0,91	240	280	X	1	M 16 01	F	B	B	E	X	1	M 16 01	F	B	B	F
XV-1M/1.2	1,17	250	290	X	1	M 17 01	F	B	B	E	X	1	M 17 01	F	B	B	F
XV-1M/1.7	1,56	250	290	X	1	M 18 01	F	B	B	E	X	1	M 18 01	F	B	B	F
XV-1M/2.2	2,08	250	290	X	1	M 20 01	F	B	B	E	X	1	M 20 01	F	B	B	F
XV-1M/2.6	2,60	250	300	X	1	M 21 01	F	B	B	E	X	1	M 21 01	F	B	B	F
XV-1M/3.2	3,12	250	300	X	1	M 23 01	F	B	B	E	X	1	M 23 01	F	B	B	F
XV-1M/3.8	3,64	250	300	X	1	M 25 01	F	B	B	E	X	1	M 25 01	F	B	B	F
XV-1M/4.3	4,16	250	300	X	1	M 27 01	F	B	B	E	X	1	M 27 01	F	B	B	F
XV-1M/4.9	4,94	250	300	X	1	M 29 01	F	B	B	E	X	1	M 29 01	F	B	B	F
XV-1M/5.9	5,85	250	300	X	1	M 31 01	F	B	B	E	X	1	M 31 01	F	B	B	F
XV-1M/6.5	6,50	250	300	X	1	M 32 01	F	B	B	E	X	1	M 32 01	F	B	B	F
XV-1M/7.8	7,54	220	260	X	1	M 34 01	F	B	B	E	X	1	M 34 01	F	B	B	F
XV-1M/9.8	9,88	190	230	X	1	M 36 01	F	B	B	E	X	1	M 36 01	F	B	B	F

P1) Max. working pressure - P3) Max. peak pressure

For heavy-duty applications, it is recommended to check the admissible torque of the shaft

Dimensions table

TYPE	Weight kg	A	B	C	D	
		mm	mm	mm	IN	OUT
XV-1M/0.9	0,950	78,1	37,3	66,1	3/8" BSPP	3/8" BSPP
XV-1M/1.2	0,970	79,0	37,8	67,0	3/8" BSPP	3/8" BSPP
XV-1M/1.7	1,010	80,5	38,5	68,5	3/8" BSPP	3/8" BSPP
XV-1M/2.2	1,030	82,5	39,5	70,5	3/8" BSPP	3/8" BSPP
XV-1M/2.6	1,060	84,5	40,5	72,5	3/8" BSPP	3/8" BSPP
XV-1M/3.2	1,090	86,5	41,5	74,5	3/8" BSPP	3/8" BSPP
XV-1M/3.8	1,120	88,5	42,5	76,5	3/8" BSPP	3/8" BSPP
XV-1M/4.3	1,170	90,5	43,5	78,5	3/8" BSPP	3/8" BSPP
XV-1M/4.9	1,200	93,5	45,0	81,5	3/8" BSPP	3/8" BSPP
XV-1M/5.9	1,260	97,0	46,8	85,0	3/8" BSPP	3/8" BSPP
XV-1M/6.5	1,300	98,5	48,0	86,5	3/8" BSPP	3/8" BSPP
XV-1M/7.8	1,360	103,5	50,0	91,5	3/8" BSPP	3/8" BSPP
XV-1M/9.8	1,500	112,5	54,5	100,5	3/8" BSPP	3/8" BSPP

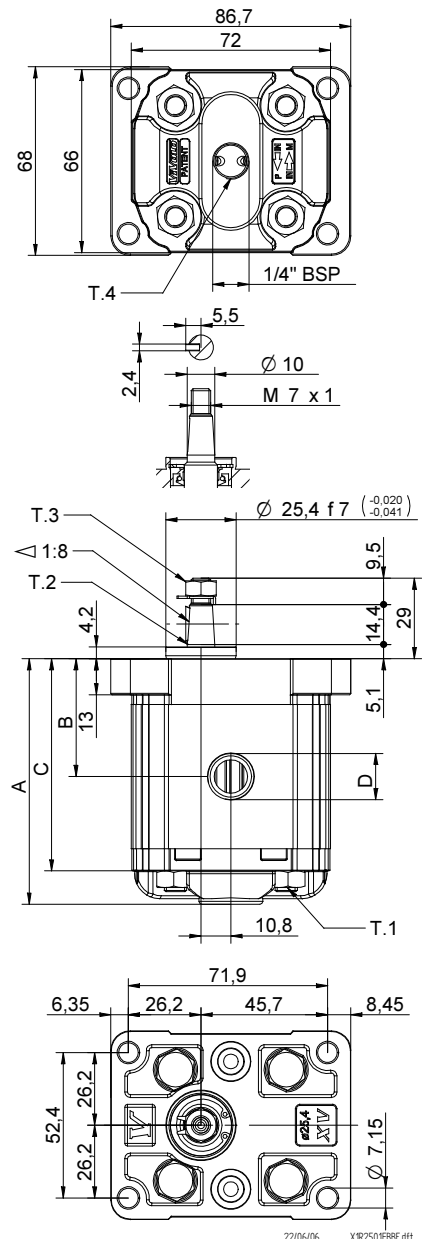

T.1 = 24.5÷29.4 [Nm] - screw tightening torque M8

T.3 = 11.5 [Nm] - torque wrench setting 11

T.2 = 43 [Nm] - admissible shaft torque (N.B. When choosing a shaft, always check the admissible torque).

T.4 = 0.3÷0.5 bar - max. drainage pressure

Table of variations

XV-1M

ø25.4 FLANGE

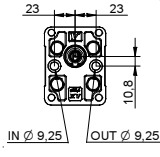
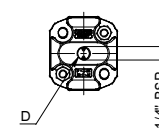
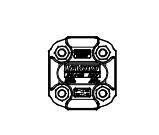
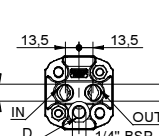
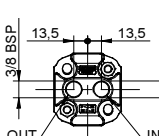
ø25.4 FLANGE		Shaft		Cover			
	01	CO001 - Tapered T.2 = 43 [Nm]	F	CF002 - Milled shank T.2 = 13.8 [Nm]	D	 External drainage	E
	04	SCF04 - Splined T.2 = 22.6 [Nm] m=1.6 Z=6 DIN 5482 - 12x9	J	SCF02 - Splined T.2 = 42.8 [Nm] m=0.75 Z=15	L	 Internal drainage	F
		SCF01 - Splined T.2 = 42.8 [Nm] m=0.75 Z=15	Q	SCF03 - Splined T.2 = 42.8 [Nm] m=0.75 Z=15	R	 IN + OUT + external	K
						 IN + OUT + internal	L

Displacement	
TYPE	CODE
XV-1M/0.9	16
XV-1M/1.2	17
XV-1M/1.7	18
XV-1M/2.2	20
XV-1M/2.6	21
XV-1M/3.2	23
XV-1M/3.8	25
XV-1M/4.3	27
XV-1M/4.9	29
XV-1M/5.9	31
XV-1M/6.5	32
XV-1M/7.8	34
XV-1M/9.8	36

Standard bodies				
Displacement cm3/rev	Standard threads			
	0.9	I - I	B - B	J - J
1.2	I - I	B - B	J - J	Z - Z
1.7	I - I	B - B	J - J	Z - Z
2.2	I - I	B - B	J - J	Z - Z
2.6	I - I	B - B	J - J	Z - Z
3.2	I - I	B - B	J - J	Z - Z
3.8	I - I	B - B	J - J	Z - Z
4.3	I - I	B - B	J - J	Z - Z
4.9	I - I	B - B	J - J	Z - Z
5.9	I - I	B - B	J - J	Z - Z
6.5	I - I	B - B	J - J	Z - Z
7.8	I - I	B - B	J - J	Z - Z
9.8	I - I	B - B	J - J	Z - Z

Table showing standard flange and thread combinations available in stock

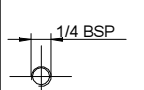
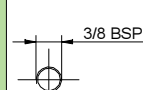
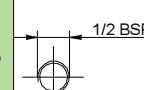
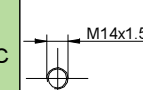
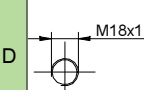
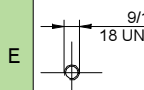
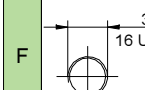
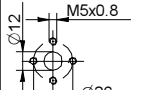
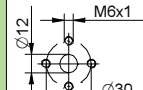
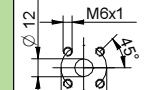
Body (threads/flanges)						
 A	 B	 C	 D	 E	 F	 G
 H	 I	 J	Closed Body	Z		

reversible motor - series XV

XV-1M

STANDARD MOTOR
ø30 FLANGE - TAPER SHAFT

X 1 M 25 07 G I I E

Series	X	series XV
Group	1	group 1
Category	M	reversible motor
Displacement	25	3.8
Flange	07	Ø30 STANDARD reversible rotation
Shaft	G	CO002 - Tapered 1:8 - ø14 - M10x1 - key thk.3
Body	IN	inlet - Ø30 Ø12 M6
	OUT	outlet - Ø30 Ø12 M6
Cover	E	with drainage 1/4" BSP

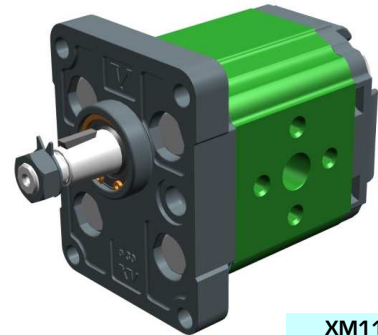

XM113

Technical data table

TYPE	Displacement cm3/rev	Max. Pressure		CODE	
		P1 bar	P3 bar	External drainage	Internal drainage
XV-1M/0.9	0,91	240	280	X 1 M 16 07 G I I E	X 1 M 16 07 G I I F
XV-1M/1.2	1,17	250	290	X 1 M 17 07 G I I E	X 1 M 17 07 G I I F
XV-1M/1.7	1,56	250	290	X 1 M 18 07 G I I E	X 1 M 18 07 G I I F
XV-1M/2.2	2,08	250	290	X 1 M 20 07 G I I E	X 1 M 20 07 G I I F
XV-1M/2.6	2,60	250	300	X 1 M 21 07 G I I E	X 1 M 21 07 G I I F
XV-1M/3.2	3,12	250	300	X 1 M 23 07 G I I E	X 1 M 23 07 G I I F
XV-1M/3.8	3,64	250	300	X 1 M 25 07 G I I E	X 1 M 25 07 G I I F
XV-1M/4.3	4,16	250	300	X 1 M 27 07 G I I E	X 1 M 27 07 G I I F
XV-1M/4.9	4,94	250	300	X 1 M 29 07 G I I E	X 1 M 29 07 G I I F
XV-1M/5.9	5,85	250	300	X 1 M 31 07 G I I E	X 1 M 31 07 G I I F
XV-1M/6.5	6,50	250	300	X 1 M 32 07 G I I E	X 1 M 32 07 G I I F
XV-1M/7.8	7,54	220	260	X 1 M 34 07 G I I E	X 1 M 34 07 G I I F
XV-1M/9.8	9,88	190	230	X 1 M 36 07 G I I E	X 1 M 36 07 G I I F

P1) Max. working pressure - P3) Max. peak pressure

For heavy-duty applications, it is recommended to check the admissible torque of the shaft

Dimensions table

TYPE	Weight kg	A	B	C	D	E	F	D	E	F
		mm	mm	mm	IN			OUT		
XV-1M/0.9	0,950	78,1	37,3	66,1	ø12	30	M6x1	ø12	30	M6x1
XV-1M/1.2	0,970	79,0	37,8	67,0	ø12	30	M6x1	ø12	30	M6x1
XV-1M/1.7	1,010	80,5	38,5	68,5	ø12	30	M6x1	ø12	30	M6x1
XV-1M/2.2	1,030	82,5	39,5	70,5	ø12	30	M6x1	ø12	30	M6x1
XV-1M/2.6	1,060	84,5	40,5	72,5	ø12	30	M6x1	ø12	30	M6x1
XV-1M/3.2	1,090	86,5	41,5	74,5	ø12	30	M6x1	ø12	30	M6x1
XV-1M/3.8	1,120	88,5	42,5	76,5	ø12	30	M6x1	ø12	30	M6x1
XV-1M/4.3	1,170	90,5	43,5	78,5	ø12	30	M6x1	ø12	30	M6x1
XV-1M/4.9	1,200	93,5	45,0	81,5	ø12	30	M6x1	ø12	30	M6x1
XV-1M/5.9	1,260	97,0	46,8	85,0	ø12	30	M6x1	ø12	30	M6x1
XV-1M/6.5	1,300	98,5	48,0	86,5	ø12	30	M6x1	ø12	30	M6x1
XV-1M/7.8	1,360	103,5	50,0	91,5	ø12	30	M6x1	ø12	30	M6x1
XV-1M/9.8	1,500	112,5	54,5	100,5	ø12	30	M6x1	ø12	30	M6x1

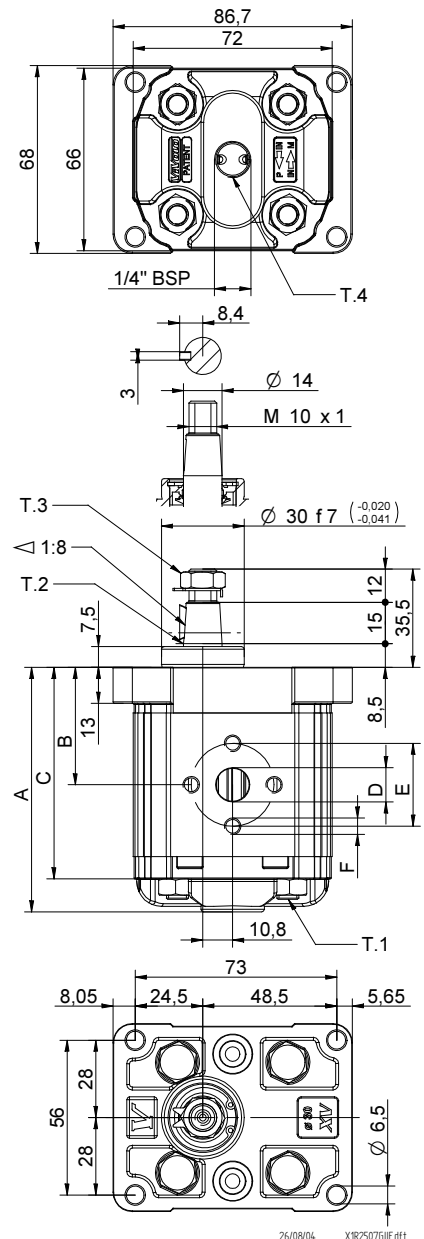

T.1 = 24.5÷29.4 [Nm] - screw tightening torque M8

T.3 = 13 [Nm] - torque wrench setting 17

T.2 = 119.8 [Nm] - admissible shaft torque (N.B. When choosing a shaft, always check the admissible torque).

T.4 = 0.3÷0.5 bar - max. drainage pressure

Table of variations

XV-1M

ø30 FLANGE

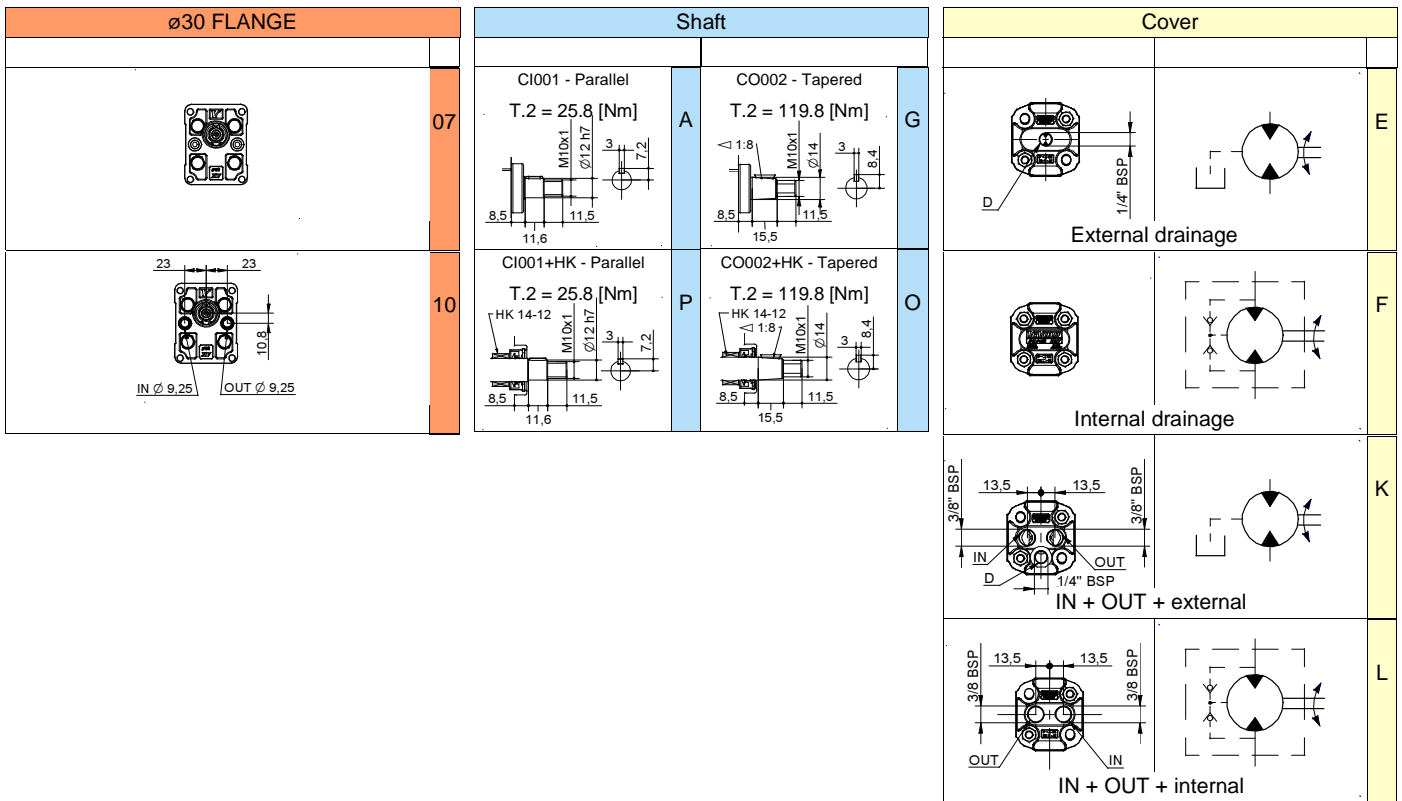

Displacement	
TYPE	CODE
XV-1M/0.9	16
XV-1M/1.2	17
XV-1M/1.7	18
XV-1M/2.2	20
XV-1M/2.6	21
XV-1M/3.2	23
XV-1M/3.8	25
XV-1M/4.3	27
XV-1M/4.9	29
XV-1M/5.9	31
XV-1M/6.5	32
XV-1M/7.8	34
XV-1M/9.8	36

Standard bodies				
Displacement cm ³ /rev	Standard threads			
	0.9	I - I	B - B	J - J
1.2	I - I	B - B	J - J	Z - Z
1.7	I - I	B - B	J - J	Z - Z
2.2	I - I	B - B	J - J	Z - Z
2.6	I - I	B - B	J - J	Z - Z
3.2	I - I	B - B	J - J	Z - Z
3.8	I - I	B - B	J - J	Z - Z
4.3	I - I	B - B	J - J	Z - Z
4.9	I - I	B - B	J - J	Z - Z
5.9	I - I	B - B	J - J	Z - Z
6.5	I - I	B - B	J - J	Z - Z
7.8	I - I	B - B	J - J	Z - Z
9.8	I - I	B - B	J - J	Z - Z

Table showing standard flange and thread combinations available in stock

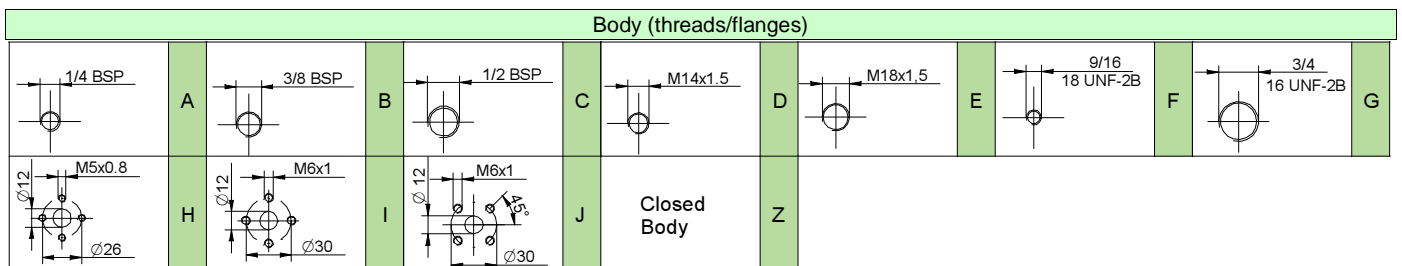

reversible motor - series XV

XV-1M

BH TYPE MOTOR
ø32 BODY-SHAPED FLANGE - MILLED SHANK

X 1 M 25 25 D B B E

Series	X	series XV
Group	1	group 1
Category	M	reversible motor
Displacement	25	3.8
Flange	25	Ø32 BH reversible rotation
Shaft	D	CF002 - Milled shank ø10 - thk.5
Body	IN	inlet - 3/8" GAS
	OUT	outlet - 3/8" GAS
Cover	E	with drainage 1/4" BSP



XM119

Technical data table

TYPE	Displacement cm3/rev	Max. Pressure		CODE	
		P1 bar	P3 bar	External drainage	Internal drainage
XV-1M/0.9	0,91	240	280	X 1 M 16 25 D B B E	X 1 M 16 25 D B B F
XV-1M/1.2	1,17	250	290	X 1 M 17 25 D B B E	X 1 M 17 25 D B B F
XV-1M/1.7	1,56	250	290	X 1 M 18 25 D B B E	X 1 M 18 25 D B B F
XV-1M/2.2	2,08	250	290	X 1 M 20 25 D B B E	X 1 M 20 25 D B B F
XV-1M/2.6	2,60	250	300	X 1 M 21 25 D B B E	X 1 M 21 25 D B B F
XV-1M/3.2	3,12	250	300	X 1 M 23 25 D B B E	X 1 M 23 25 D B B F
XV-1M/3.8	3,64	250	300	X 1 M 25 25 D B B E	X 1 M 25 25 D B B F
XV-1M/4.3	4,16	250	300	X 1 M 27 25 D B B E	X 1 M 27 25 D B B F
XV-1M/4.9	4,94	250	300	X 1 M 29 25 D B B E	X 1 M 29 25 D B B F
XV-1M/5.9	5,85	250	300	X 1 M 31 25 D B B E	X 1 M 31 25 D B B F
XV-1M/6.5	6,50	250	300	X 1 M 32 25 D B B E	X 1 M 32 25 D B B F
XV-1M/7.8	7,54	220	260	X 1 M 34 25 D B B E	X 1 M 34 25 D B B F
XV-1M/9.8	9,88	190	230	X 1 M 36 25 D B B E	X 1 M 36 25 D B B F

P1) Max. working pressure - P3) Max. peak pressure

For heavy-duty applications, it is recommended to check the admissible torque of the shaft

Dimensions table

TYPE	Weight kg	A	B	C	D	
		mm	mm	mm	IN	OUT
XV-1M/0.9	0,950	77,1	36,3	65,1	3/8" BSPP	3/8" BSPP
XV-1M/1.2	0,970	78,0	36,8	66,0	3/8" BSPP	3/8" BSPP
XV-1M/1.7	1,010	79,5	37,5	67,5	3/8" BSPP	3/8" BSPP
XV-1M/2.2	1,030	81,5	38,5	69,5	3/8" BSPP	3/8" BSPP
XV-1M/2.6	1,060	83,5	39,5	71,5	3/8" BSPP	3/8" BSPP
XV-1M/3.2	1,090	85,5	40,5	73,5	3/8" BSPP	3/8" BSPP
XV-1M/3.8	1,120	87,5	41,5	75,5	3/8" BSPP	3/8" BSPP
XV-1M/4.3	1,170	89,5	42,5	77,5	3/8" BSPP	3/8" BSPP
XV-1M/4.9	1,200	92,5	44,0	80,5	3/8" BSPP	3/8" BSPP
XV-1M/5.9	1,260	96,0	45,8	84,0	3/8" BSPP	3/8" BSPP
XV-1M/6.5	1,300	97,5	47,0	85,5	3/8" BSPP	3/8" BSPP
XV-1M/7.8	1,360	102,5	49,0	90,5	3/8" BSPP	3/8" BSPP
XV-1M/9.8	1,500	111,5	53,5	99,5	3/8" BSPP	3/8" BSPP

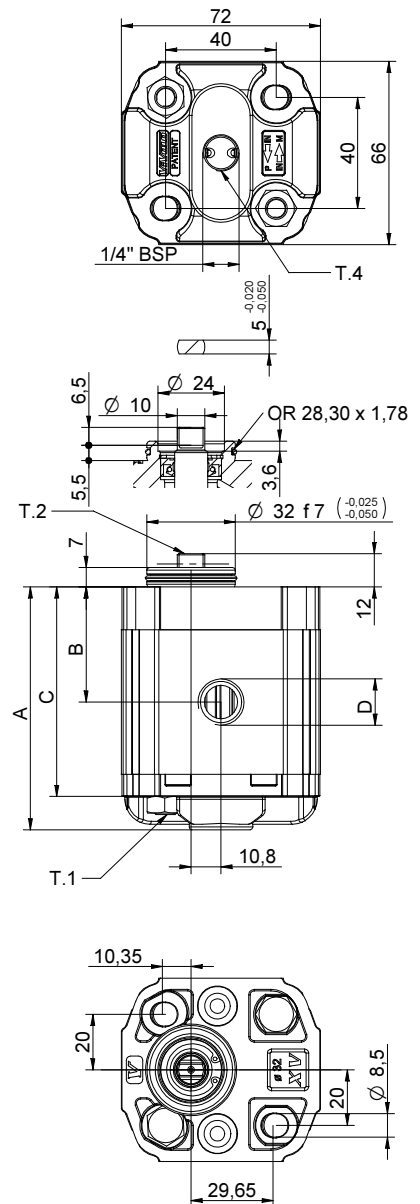

26/08/04 X1R25Z5DBBE.dft

T.1 = 24.5÷29.4 [Nm] - screw tightening torque M8

T.2 = 13.8 [Nm] - admissible shaft torque (N.B. When choosing a shaft, always check the admissible torque).

T.4 = 0.3÷0.5 bar - max. drainage pressure

Table of variations

XV-1M

ø32 "BH" Body-Shaped FLANGE

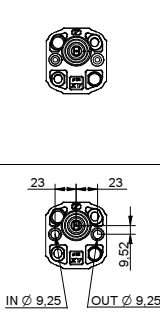
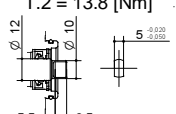
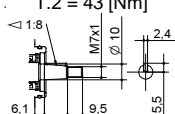
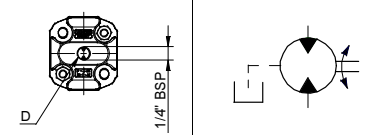
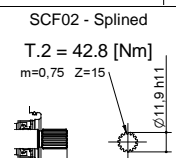
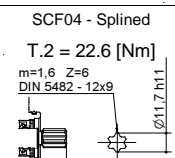
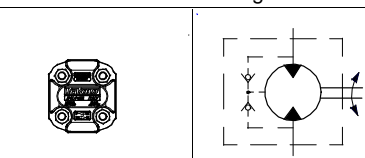
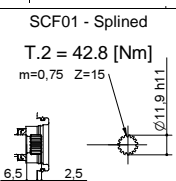
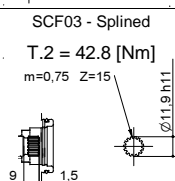
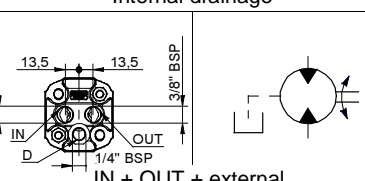
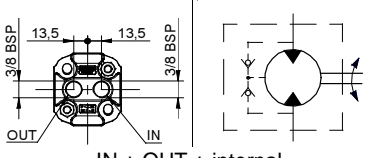
ø32 "BH" Body-Shaped FLANGE		Shaft				Cover	
	25	CF002 - Milled shank T.2 = 13.8 [Nm] 	D	CO001 - Tapered T.2 = 43 [Nm] 	F	 External drainage	E
	28	SCF02 - Splined T.2 = 42.8 [Nm] m=0,75 Z=15 	L	SCF04 - Splined T.2 = 22.6 [Nm] m=1,6 Z=6 DIN 5482 - 12x9 	J	 Internal drainage	F
		SCF01 - Splined T.2 = 42.8 [Nm] m=0,75 Z=15 	Q	SCF03 - Splined T.2 = 42.8 [Nm] m=0,75 Z=15 	R	 IN + OUT + external	K
						 IN + OUT + internal	L

Displacement	
TYPE	CODE
XV-1M/0.9	16
XV-1M/1.2	17
XV-1M/1.7	18
XV-1M/2.2	20
XV-1M/2.6	21
XV-1M/3.2	23
XV-1M/3.8	25
XV-1M/4.3	27
XV-1M/4.9	29
XV-1M/5.9	31
XV-1M/6.5	32
XV-1M/7.8	34
XV-1M/9.8	36

Standard bodies					
Displacement cm3/rev	Standard threads				
	0.9	I - I	B - B	J - J	Z - Z
1.2	I - I	B - B	J - J	Z - Z	
1.7	I - I	B - B	J - J	Z - Z	
2.2	I - I	B - B	J - J	Z - Z	
2.6	I - I	B - B	J - J	Z - Z	
3.2	I - I	B - B	J - J	Z - Z	
3.8	I - I	B - B	J - J	Z - Z	
4.3	I - I	B - B	J - J	Z - Z	
4.9	I - I	B - B	J - J	Z - Z	
5.9	I - I	B - B	J - J	Z - Z	
6.5	I - I	B - B	J - J	Z - Z	
7.8	I - I	B - B	J - J	Z - Z	
9.8	I - I	B - B	J - J	Z - Z	

Table showing standard flange and thread combinations available in stock

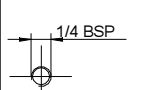
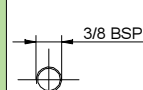
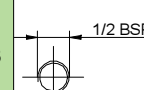
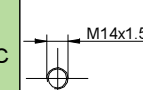
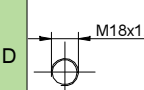
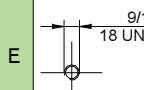
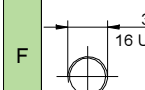
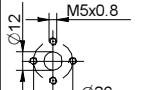
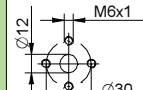
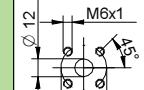
Body (threads/flanges)													
	A		B		C		D		E		F		G
	H		I		J	Closed Body	Z						

reversible motor - series XV

XV-1M

HY TYPE MOTOR
 ø32 BODY-SHAPED FLANGE - MILLED SHANK

X 1 M 25 31 D B B E

Series	X	series XV
Group	1	group 1
Category	M	reversible motor
Displacement	25	3.8
Flange	31	Ø32 HY reversible rotation with inlet
Shaft	D	CF002 - Milled shank ø10 - thk.5
Body	IN	inlet - 3/8" GAS
	OUT	outlet - 3/8" GAS
Cover	E	with drainage 1/4" BSP



XM140

Technical data table

TYPE	Displacement cm3/rev	Max. Pressure		CODE	
		P1 bar	P3 bar	External drainage	Internal drainage
XV-1M/0.9	0,91	240	280	X 1 M 16 31 D B B E	X 1 M 16 31 D B B F
XV-1M/1.2	1,17	250	290	X 1 M 17 31 D B B E	X 1 M 17 31 D B B F
XV-1M/1.7	1,56	250	290	X 1 M 18 31 D B B E	X 1 M 18 31 D B B F
XV-1M/2.2	2,08	250	290	X 1 M 20 31 D B B E	X 1 M 20 31 D B B F
XV-1M/2.6	2,60	250	300	X 1 M 21 31 D B B E	X 1 M 21 31 D B B F
XV-1M/3.2	3,12	250	300	X 1 M 23 31 D B B E	X 1 M 23 31 D B B F
XV-1M/3.8	3,64	250	300	X 1 M 25 31 D B B E	X 1 M 25 31 D B B F
XV-1M/4.3	4,16	250	300	X 1 M 27 31 D B B E	X 1 M 27 31 D B B F
XV-1M/4.9	4,94	250	300	X 1 M 29 31 D B B E	X 1 M 29 31 D B B F
XV-1M/5.9	5,85	250	300	X 1 M 31 31 D B B E	X 1 M 31 31 D B B F
XV-1M/6.5	6,50	250	300	X 1 M 32 31 D B B E	X 1 M 32 31 D B B F
XV-1M/7.8	7,54	220	260	X 1 M 34 31 D B B E	X 1 M 34 31 D B B F
XV-1M/9.8	9,88	190	230	X 1 M 36 31 D B B E	X 1 M 36 31 D B B F

P1) Max. working pressure - P3) Max. peak pressure

For heavy-duty applications, it is recommended to check the admissible torque of the shaft

Dimensions table

TYPE	Weight kg	A	B	C	D	D
		mm	mm	mm	IN	OUT
XV-1M/0.9	0,950	77,1	36,3	65,1	3/8" BSPP	3/8" BSPP
XV-1M/1.2	0,970	78,0	36,8	66,0	3/8" BSPP	3/8" BSPP
XV-1M/1.7	1,010	79,5	37,5	67,5	3/8" BSPP	3/8" BSPP
XV-1M/2.2	1,030	81,5	38,5	69,5	3/8" BSPP	3/8" BSPP
XV-1M/2.6	1,060	83,5	39,5	71,5	3/8" BSPP	3/8" BSPP
XV-1M/3.2	1,090	85,5	40,5	73,5	3/8" BSPP	3/8" BSPP
XV-1M/3.8	1,120	87,5	41,5	75,5	3/8" BSPP	3/8" BSPP
XV-1M/4.3	1,170	89,5	42,5	77,5	3/8" BSPP	3/8" BSPP
XV-1M/4.9	1,200	92,5	44,0	80,5	3/8" BSPP	3/8" BSPP
XV-1M/5.9	1,260	96,0	45,8	84,0	3/8" BSPP	3/8" BSPP
XV-1M/6.5	1,300	97,5	47,0	85,5	3/8" BSPP	3/8" BSPP
XV-1M/7.8	1,360	102,5	49,0	90,5	3/8" BSPP	3/8" BSPP
XV-1M/9.8	1,500	111,5	53,5	99,5	3/8" BSPP	3/8" BSPP

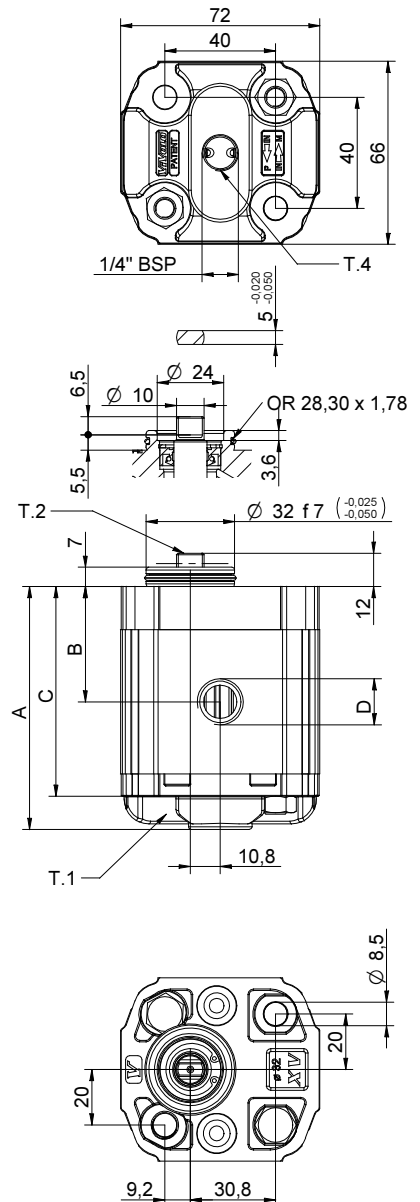

26/08/04 X1R253 1888E.dft

T.1 = 24.5÷29.4 [Nm] - screw tightening torque M8

T.2 = 13.8 [Nm] - admissible shaft torque (N.B. When choosing a shaft, always check the admissible torque).

T.4 = 0.3÷0.5 bar - max. drainage pressure

Table of variations

XV-1M

ø32 "HY" Body-Shaped FLANGE

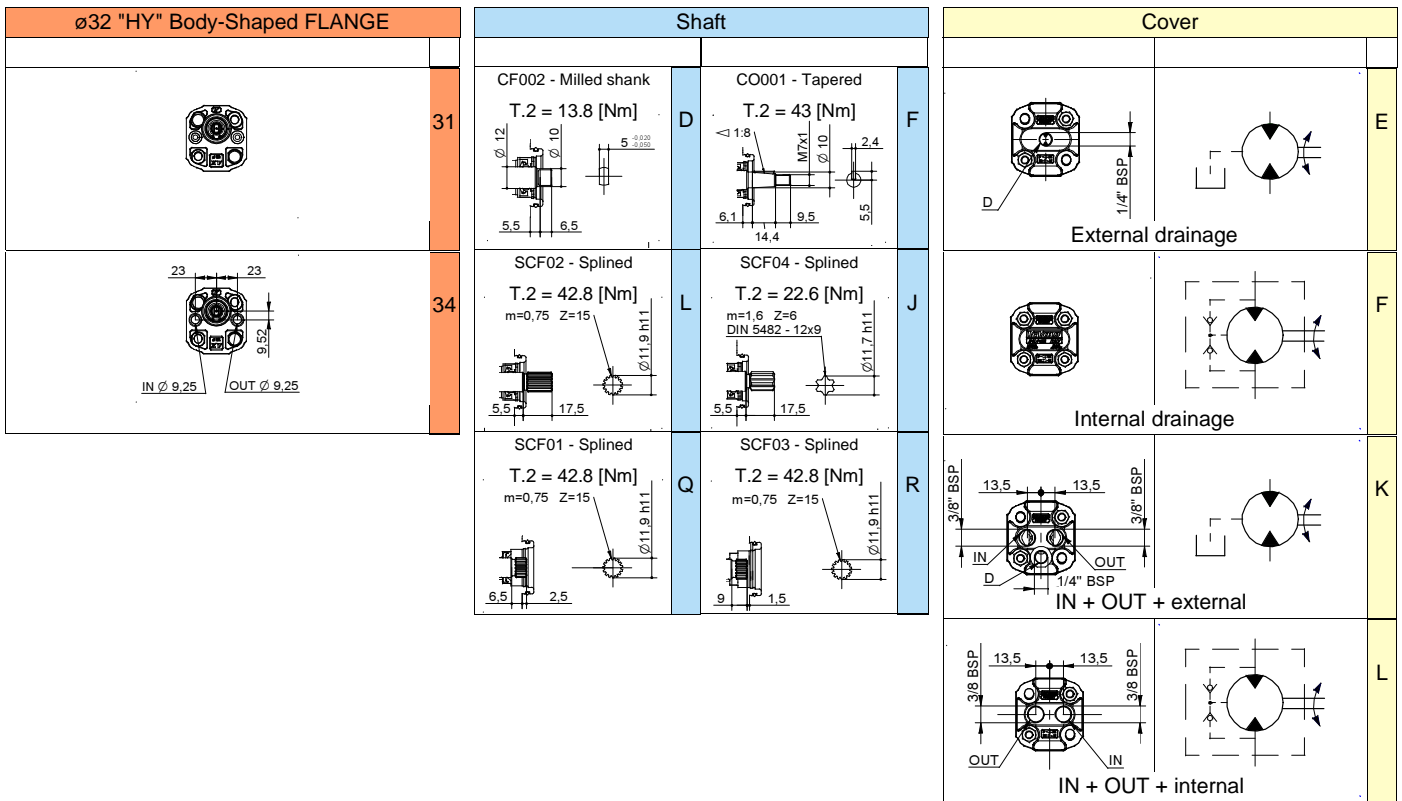

Displacement	
TYPE	CODE
XV-1M/0.9	16
XV-1M/1.2	17
XV-1M/1.7	18
XV-1M/2.2	20
XV-1M/2.6	21
XV-1M/3.2	23
XV-1M/3.8	25
XV-1M/4.3	27
XV-1M/4.9	29
XV-1M/5.9	31
XV-1M/6.5	32
XV-1M/7.8	34
XV-1M/9.8	36

Standard bodies					
Displacement cm3/rev	Standard threads				
	0.9	I - I	B - B	J - J	Z - Z
1.2	I - I	B - B	J - J	Z - Z	
1.7	I - I	B - B	J - J	Z - Z	
2.2	I - I	B - B	J - J	Z - Z	
2.6	I - I	B - B	J - J	Z - Z	
3.2	I - I	B - B	J - J	Z - Z	
3.8	I - I	B - B	J - J	Z - Z	
4.3	I - I	B - B	J - J	Z - Z	
4.9	I - I	B - B	J - J	Z - Z	
5.9	I - I	B - B	J - J	Z - Z	
6.5	I - I	B - B	J - J	Z - Z	
7.8	I - I	B - B	J - J	Z - Z	
9.8	I - I	B - B	J - J	Z - Z	

Table showing standard flange and thread combinations available in stock

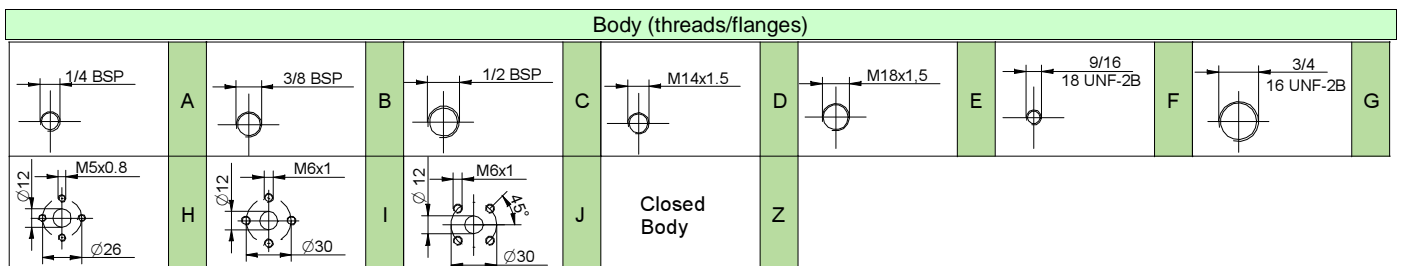

reversible motor - series XV

STANDARD GERMAN "BH" TYPE MOTOR
 ø32 BODY-SHAPED FLANGE - MILLED SHANK

XV-1M

X 1 M 25 19 C B B E

Series	X	series XV
Group	1	group 1
Category	M	reversible motor
Displacement	25	3.8
Flange	19	Ø32 BH reversible rotation
Shaft	C	CF001 - Milled shank ø10 - thk.5 ("BH" Standard German)
Body	IN	inlet - 3/8" GAS
	OUT	outlet - 3/8" GAS
Cover	E	with drainage 1/4" BSP

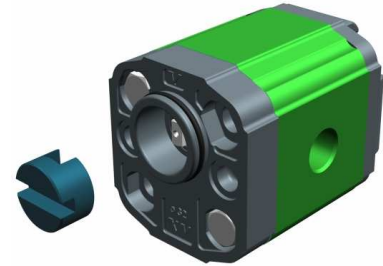

XM161

Technical data table

TYPE	Displacement cm3/rev	Max. Pressure		CODE	
		P1 bar	P3 bar	External drainage	Internal drainage
XV-1M/0.9	0,91	240	280	X 1 M 16 19 C B B E	X 1 M 16 19 C B B F
XV-1M/1.2	1,17	250	290	X 1 M 17 19 C B B E	X 1 M 17 19 C B B F
XV-1M/1.7	1,56	250	290	X 1 M 18 19 C B B E	X 1 M 18 19 C B B F
XV-1M/2.2	2,08	250	290	X 1 M 20 19 C B B E	X 1 M 20 19 C B B F
XV-1M/2.6	2,60	250	300	X 1 M 21 19 C B B E	X 1 M 21 19 C B B F
XV-1M/3.2	3,12	250	300	X 1 M 23 19 C B B E	X 1 M 23 19 C B B F
XV-1M/3.8	3,64	250	300	X 1 M 25 19 C B B E	X 1 M 25 19 C B B F
XV-1M/4.3	4,16	250	300	X 1 M 27 19 C B B E	X 1 M 27 19 C B B F
XV-1M/4.9	4,94	250	300	X 1 M 29 19 C B B E	X 1 M 29 19 C B B F
XV-1M/5.9	5,85	250	300	X 1 M 31 19 C B B E	X 1 M 31 19 C B B F
XV-1M/6.5	6,50	250	300	X 1 M 32 19 C B B E	X 1 M 32 19 C B B F
XV-1M/7.8	7,54	220	260	X 1 M 34 19 C B B E	X 1 M 34 19 C B B F
XV-1M/9.8	9,88	190	230	X 1 M 36 19 C B B E	X 1 M 36 19 C B B F

P1) Max. working pressure - P3) Max. peak pressure

For heavy-duty applications, it is recommended to check the admissible torque of the shaft

Dimensions table

TYPE	Weight kg	A	B	C	D	
		mm	mm	mm	IN	OUT
XV-1M/0.9	0,950	77,1	36,3	65,1	3/8" BSPP	3/8" BSPP
XV-1M/1.2	0,970	78,0	36,8	66,0	3/8" BSPP	3/8" BSPP
XV-1M/1.7	1,010	79,5	37,5	67,5	3/8" BSPP	3/8" BSPP
XV-1M/2.2	1,030	81,5	38,5	69,5	3/8" BSPP	3/8" BSPP
XV-1M/2.6	1,060	83,5	39,5	71,5	3/8" BSPP	3/8" BSPP
XV-1M/3.2	1,090	85,5	40,5	73,5	3/8" BSPP	3/8" BSPP
XV-1M/3.8	1,120	87,5	41,5	75,5	3/8" BSPP	3/8" BSPP
XV-1M/4.3	1,170	89,5	42,5	77,5	3/8" BSPP	3/8" BSPP
XV-1M/4.9	1,200	92,5	44,0	80,5	3/8" BSPP	3/8" BSPP
XV-1M/5.9	1,260	96,0	45,8	84,0	3/8" BSPP	3/8" BSPP
XV-1M/6.5	1,300	97,5	47,0	85,5	3/8" BSPP	3/8" BSPP
XV-1M/7.8	1,360	102,5	49,0	90,5	3/8" BSPP	3/8" BSPP
XV-1M/9.8	1,500	111,5	53,5	99,5	3/8" BSPP	3/8" BSPP

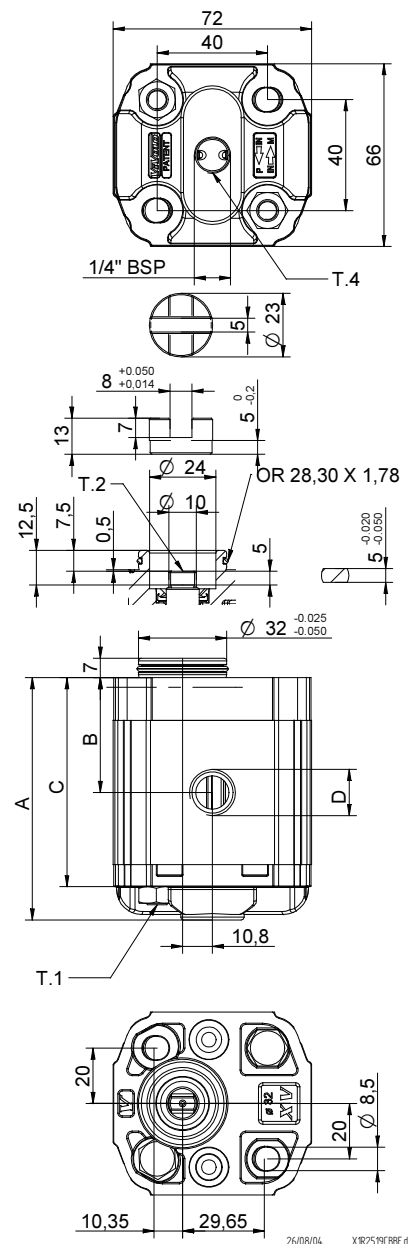

T.1 = 24.5÷29.4 [Nm] - screw tightening torque M8

T.2 = 13.8 [Nm] - admissible shaft torque (N.B. When choosing a shaft, always check the admissible torque).

T.4 = 0.3÷0.5 bar - max. drainage pressure

Table of variations

XV-1M

Standard German ø32 "BH" FLANGE

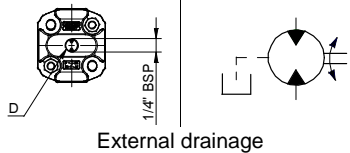
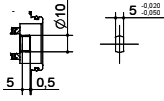
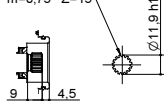
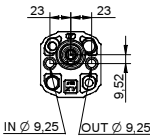
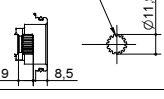
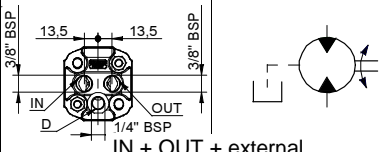
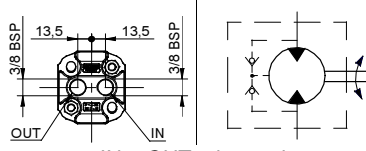
Standard German ø32 "BH" FLANGE		Shaft		Cover		
	19	CF001 - Milled shank T.2 = 13.8 [Nm]	C	SCF01 - Splined T.2 = 42.8 [Nm]	 External drainage	E
				SCF03 - Splined T.2 = 42.8 [Nm]		
 IN Ø 9.25 OUT Ø 9.25	22		 IN + OUT + external		K	
		 IN + OUT + internal		L		

Displacement	
TYPE	CODE
XV-1M/0.9	16
XV-1M/1.2	17
XV-1M/1.7	18
XV-1M/2.2	20
XV-1M/2.6	21
XV-1M/3.2	23
XV-1M/3.8	25
XV-1M/4.3	27
XV-1M/4.9	29
XV-1M/5.9	31
XV-1M/6.5	32
XV-1M/7.8	34
XV-1M/9.8	36

Displacement cm3/rev	Standard threads			
	I - I	B - B	J - J	Z - Z
0.9	I - I	B - B	J - J	Z - Z
1.2	I - I	B - B	J - J	Z - Z
1.7	I - I	B - B	J - J	Z - Z
2.2	I - I	B - B	J - J	Z - Z
2.6	I - I	B - B	J - J	Z - Z
3.2	I - I	B - B	J - J	Z - Z
3.8	I - I	B - B	J - J	Z - Z
4.3	I - I	B - B	J - J	Z - Z
4.9	I - I	B - B	J - J	Z - Z
5.9	I - I	B - B	J - J	Z - Z
6.5	I - I	B - B	J - J	Z - Z
7.8	I - I	B - B	J - J	Z - Z
9.8	I - I	B - B	J - J	Z - Z

Table showing standard flange and thread combinations available in stock

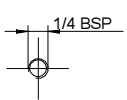
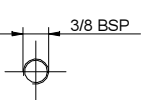
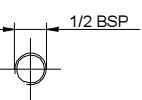
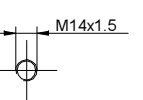
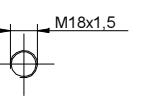
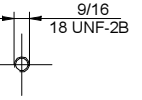
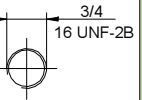
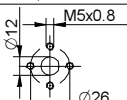
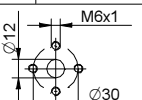
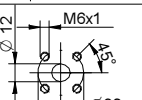
Body (threads/flanges)													
	A		B		C		D		E		F		G
	H		I		J	Closed Body	Z						

reversible motor - series XV

XV-1M

SAE AA TYPE MOTOR
 ø50.8 FLANGE - PARALLEL SHAFT

X 1 M 25 61 B B B E

Series	X	series XV
Group	1	group 1
Category	M	reversible motor
Displacement	25	3.8
Flange	61	Ø50.8 SAE AA reversible rotation
Shaft	B	CI002 - Parallel ø12.7 - key thk. 3.2 (SAE AA)
Body	IN	inlet - 3/8" GAS
	OUT	outlet - 3/8" GAS
Cover	E	with drainage 1/4" BSP

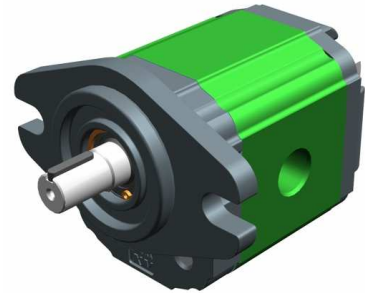

XM168

Technical data table

TYPE	Displacement cm3/rev	Max. Pressure		CODE	
		P1 bar	P3 bar	External drainage	Internal drainage
XV-1M/0.9	0,91	240	280	X 1 M 16 61 B B B E	X 1 M 16 61 B B B F
XV-1M/1.2	1,17	250	290	X 1 M 17 61 B B B E	X 1 M 17 61 B B B F
XV-1M/1.7	1,56	250	290	X 1 M 18 61 B B B E	X 1 M 18 61 B B B F
XV-1M/2.2	2,08	250	290	X 1 M 20 61 B B B E	X 1 M 20 61 B B B F
XV-1M/2.6	2,60	250	300	X 1 M 21 61 B B B E	X 1 M 21 61 B B B F
XV-1M/3.2	3,12	250	300	X 1 M 23 61 B B B E	X 1 M 23 61 B B B F
XV-1M/3.8	3,64	250	300	X 1 M 25 61 B B B E	X 1 M 25 61 B B B F
XV-1M/4.3	4,16	250	300	X 1 M 27 61 B B B E	X 1 M 27 61 B B B F
XV-1M/4.9	4,94	250	300	X 1 M 29 61 B B B E	X 1 M 29 61 B B B F
XV-1M/5.9	5,85	250	300	X 1 M 31 61 B B B E	X 1 M 31 61 B B B F
XV-1M/6.5	6,50	250	300	X 1 M 32 61 B B B E	X 1 M 32 61 B B B F
XV-1M/7.8	7,54	220	260	X 1 M 34 61 B B B E	X 1 M 34 61 B B B F
XV-1M/9.8	9,88	190	230	X 1 M 36 61 B B B E	X 1 M 36 61 B B B F

P1) Max. working pressure - P3) Max. peak pressure

For heavy-duty applications, it is recommended to check the admissible torque of the shaft

Dimensions table

TYPE	Weight kg	A	B	C	D	D
		mm	mm	mm	IN	OUT
XV-1M/0.9	1,000	82,6	41,8	70,6	3/8" BSPP	3/8" BSPP
XV-1M/1.2	1,020	83,5	42,3	71,5	3/8" BSPP	3/8" BSPP
XV-1M/1.7	1,060	85,0	43,0	73,0	3/8" BSPP	3/8" BSPP
XV-1M/2.2	1,080	87,0	44,0	75,0	3/8" BSPP	3/8" BSPP
XV-1M/2.6	1,110	89,0	45,0	77,0	3/8" BSPP	3/8" BSPP
XV-1M/3.2	1,140	91,0	46,0	79,0	3/8" BSPP	3/8" BSPP
XV-1M/3.8	1,170	93,0	47,0	81,0	3/8" BSPP	3/8" BSPP
XV-1M/4.3	1,220	95,0	48,0	83,0	3/8" BSPP	3/8" BSPP
XV-1M/4.9	1,250	98,0	49,5	86,0	3/8" BSPP	3/8" BSPP
XV-1M/5.9	1,310	101,5	51,3	89,5	3/8" BSPP	3/8" BSPP
XV-1M/6.5	1,350	105,0	52,5	93,0	3/8" BSPP	3/8" BSPP
XV-1M/7.8	1,410	108,0	54,5	96,0	3/8" BSPP	3/8" BSPP
XV-1M/9.8	1,550	117,0	59,0	105,0	3/8" BSPP	3/8" BSPP

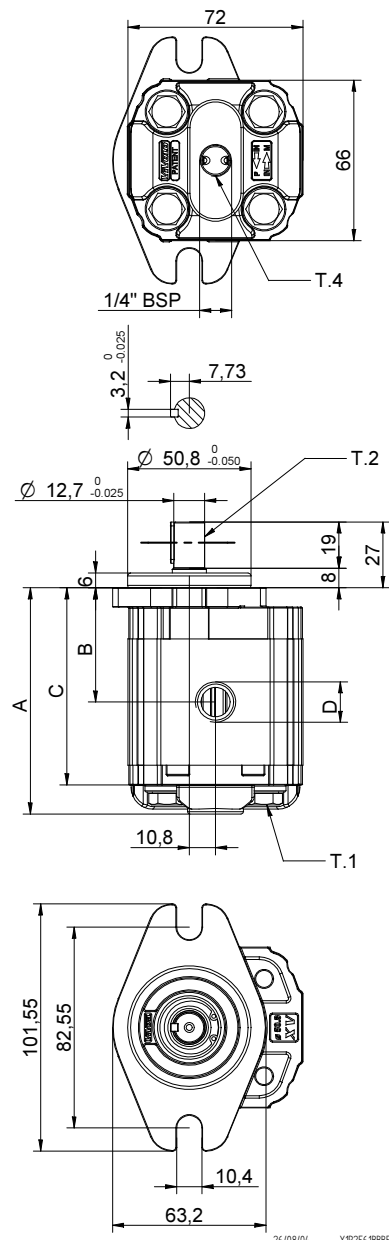

T.1 = 24.5÷29.4 [Nm] - screw tightening torque M8

T.2 = 32.8 [Nm] - admissible shaft torque (N.B. When choosing a shaft, always check the admissible torque).

T.4 = 0.3÷0.5 bar - max. drainage pressure

Table of variations

XV-1M

ø50.8 FLANGE "SAE AA"

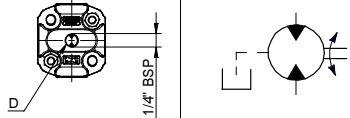
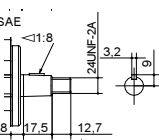
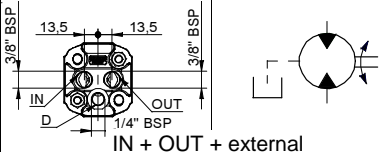
ø50.8 FLANGE "SAE AA"		Shaft				Cover	
	61	CI001 - Parallel T.2 = 25.8 [Nm]	A	CI002 - Parallel T.2 = 32.8 [Nm]	B	 External drainage	E
		CF003 - Milled shank T.2 = 25.9 [Nm]	E	CO002 - Tapered T.2 = 119.8 [Nm]	G		
			I	SCF05 - Splined T.2 = 32.2 [Nm]	K	 IN + OUT + external	K
		CO002+HK - Tapered T.2 = 119.8 [Nm]	O	CI001+HK - Parallel T.2 = 25.8 [Nm]	P		

Displacement	
TYPE	CODE
XV-1M/0.9	16
XV-1M/1.2	17
XV-1M/1.7	18
XV-1M/2.2	20
XV-1M/2.6	21
XV-1M/3.2	23
XV-1M/3.8	25
XV-1M/4.3	27
XV-1M/4.9	29
XV-1M/5.9	31
XV-1M/6.5	32
XV-1M/7.8	34
XV-1M/9.8	36

Standard bodies				
Displacement cm3/rev	Standard threads			
	0.9	I - I	B - B	J - J
1.2	I - I	B - B	J - J	Z - Z
1.7	I - I	B - B	J - J	Z - Z
2.2	I - I	B - B	J - J	Z - Z
2.6	I - I	B - B	J - J	Z - Z
3.2	I - I	B - B	J - J	Z - Z
3.8	I - I	B - B	J - J	Z - Z
4.3	I - I	B - B	J - J	Z - Z
4.9	I - I	B - B	J - J	Z - Z
5.9	I - I	B - B	J - J	Z - Z
6.5	I - I	B - B	J - J	Z - Z
7.8	I - I	B - B	J - J	Z - Z
9.8	I - I	B - B	J - J	Z - Z

Table showing standard flange and thread combinations available in stock

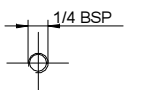
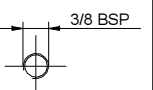
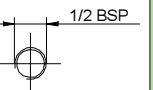
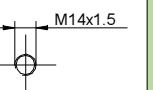
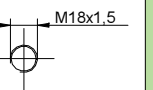
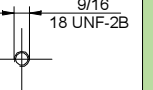
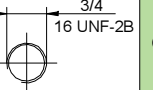
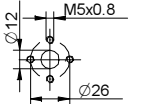
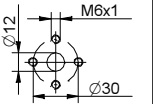
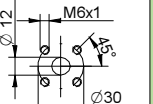
Body (threads/flanges)													
	A		B		C		D		E		F		G
	H		I		J	Closed Body	Z						

reversible motor - series XV

XV-2M

STANDARD EUROPEAN MOTOR
 ø36.5 FLANGE - TAPER SHAFT



X 2 M 51 01 E P P E

Series	X	series XV
Group	2	group 2
Category	M	reversible motor
Displacement	51	17
Flange	01	Ø36.5 STANDARD EUROPEAN reversible rotation
Shaft	E	CO001 - Tapered 1:8 - ø17.4 - M12x1.5 - key thk.4
Body	IN	inlet - Ø40 Ø20 M8
	OUT	outlet - Ø40 Ø20 M8
Cover	E	with external drainage

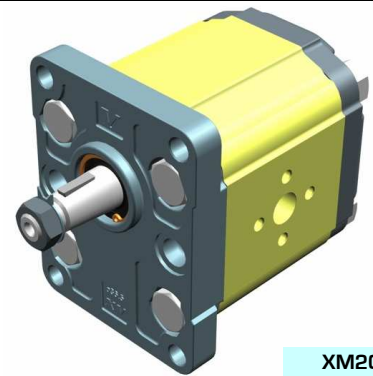

XM201

Technical data table						
TYPE	Displacement cm3/rev	Max. Pressure		CODE		
		P1 bar	P3 bar	External drainage		Internal drainage
XV-2M/04	4,20	260	300	X 2 M 41 01 E O O E	X 2 M 41 01 E O O F	
XV-2M/06	6,00	260	300	X 2 M 43 01 E O O E	X 2 M 43 01 E O O F	
XV-2M/09	8,40	260	300	X 2 M 45 01 E O O E	X 2 M 45 01 E O O F	
XV-2M/11	10,80	260	300	X 2 M 47 01 E O O E	X 2 M 47 01 E O O F	
XV-2M/14	14,40	250	290	X 2 M 49 01 E P P E	X 2 M 49 01 E P P F	
XV-2M/17	16,80	230	270	X 2 M 51 01 E P P E	X 2 M 51 01 E P P F	
XV-2M/19	19,20	210	250	X 2 M 53 01 E P P E	X 2 M 53 01 E P P F	
XV-2M/22	22,80	200	240	X 2 M 55 01 E P P E	X 2 M 55 01 E P P F	
XV-2M/26	26,20	170	210	X 2 M 57 01 E Q P E	X 2 M 57 01 E Q P F	
XV-2M/30	30,00	160	200	X 2 M 59 01 E Q P E	X 2 M 59 01 E Q P F	
XV-2M/34	34,20	150	190	X 2 M 61 01 E Q P E	X 2 M 61 01 E Q P F	
XV-2M/40	39,60	140	180	X 2 M 63 01 E Q P E	X 2 M 63 01 E Q P F	

P1) Max. working pressure - P3) Max. peak pressure

For heavy-duty applications, it is recommended to check the admissible torque of the shaft

Dimensions table										
TYPE	Weight kg	A	B	C	D	E	F	D	E	F
		mm	mm	mm	IN			OUT		
XV-2M/04	2,200	87,2	41,7	77,2	ø13,5	30	M6x1	ø13,5	30	M6x1
XV-2M/06	2,300	90,2	43,2	80,2	ø13,5	30	M6x1	ø13,5	30	M6x1
XV-2M/09	2,400	94,2	45,2	84,2	ø13,5	30	M6x1	ø13,5	30	M6x1
XV-2M/11	2,500	98,2	47,2	88,2	ø13,5	30	M6x1	ø13,5	30	M6x1
XV-2M/14	2,700	104,2	50,2	94,2	ø20	40	M8X1,25	ø20	40	M8X1,25
XV-2M/17	2,800	108,2	52,2	98,2	ø20	40	M8X1,25	ø20	40	M8X1,25
XV-2M/19	2,900	112,2	54,2	102,2	ø20	40	M8X1,25	ø20	40	M8X1,25
XV-2M/22	3,050	118,2	57,2	108,2	ø20	40	M8X1,25	ø20	40	M8X1,25
XV-2M/26	3,150	122,2	59,2	112,2	ø23,5	40	M8X1,25	ø20	40	M8X1,25
XV-2M/30	3,400	130,2	63,2	120,2	ø23,5	40	M8X1,25	ø20	40	M8X1,25
XV-2M/34	3,600	137,2	66,7	127,2	ø23,5	40	M8X1,25	ø20	40	M8X1,25
XV-2M/40	3,800	146,2	71,2	136,2	ø23,5	40	M8X1,25	ø20	40	M8X1,25

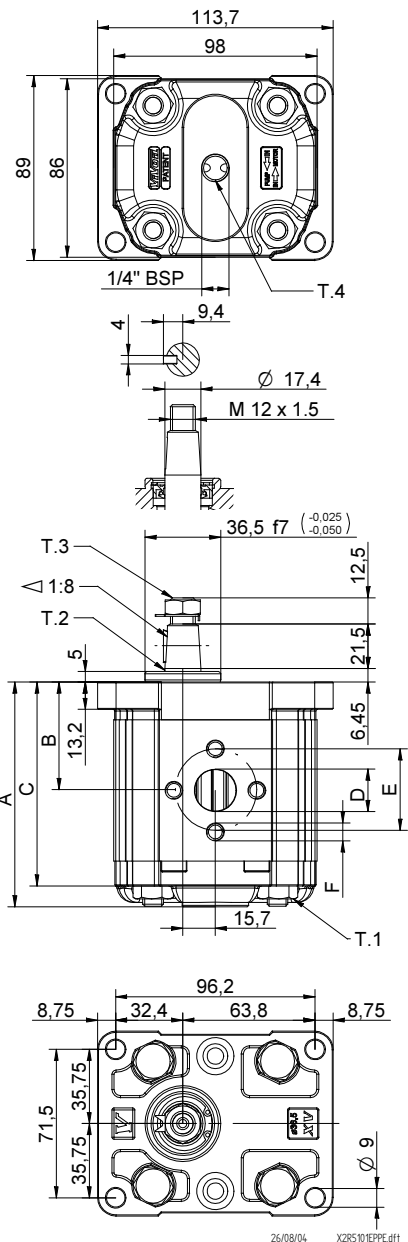

T.1 = 54÷58.9 [Nm] - screw tightening torque M10

T.3 = 40 [Nm] - torque wrench setting 19







T.2 = 233.2 [Nm] - admissible shaft torque (N.B. When choosing a shaft, always check the admissible torque).

T.4 = 0.3÷0.5 bar - max. drainage pressure

Table of variations

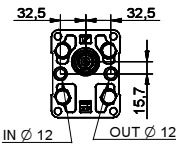
XV-2M

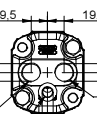
ø36.5 FLANGE

ø36.5 FLANGE		Shaft				Cover	
	01	CI001 - Parallel T.2 = 44.1 [Nm]	A	CI002 - Parallel T.2 = 67.5 [Nm]	B	 External drainage	E
		 IN Ø 12 OUT Ø 12	CO001 - Tapered T.2 = 233.2 [Nm]	E	CO002 - Tapered T.2 = 233.2 [Nm]		
 D Ø 12	05	SCF02 - Splined T.2 = 86.1 [Nm] m=1.6 Z=9 DIN 5482 - 17x14	G	SCF03 - Splined T.2 = 86.1 [Nm] m=1.6 Z=9 DIN 5482 - 17x14	H	 IN + OUT + external	K
		SCF04 - Splined T.2 = 67.1 [Nm] SAE J 498 9T 16/32 DP	I	SCF01 - Splined T.2 = 86.2 [Nm] m=1.6 Z=9 DIN 5482 - 17x14	L		
						 Flange drainage	P

Displacement	
TYPE	CODE
XV-2M/04	41
XV-2M/06	43
XV-2M/09	45
XV-2M/11	47
XV-2M/14	49
XV-2M/17	51
XV-2M/19	53
XV-2M/22	55
XV-2M/26	57
XV-2M/30	59
XV-2M/34	61
XV-2M/40	63

Standard bodies				
Displacement cm ³ /rev	Standard threads			
	4	O - O	R - R	B - B
6	O - O	R - R	B - B	Z - Z
9	O - O	R - R	B - B	Z - Z
11	O - O	R - R	B - B	Z - Z
14	P - P	R - R	C - C	Z - Z
17	P - P	R - R	C - C	Z - Z
19	P - P	R - R	C - C	Z - Z
22	P - P	R - R	C - C	Z - Z
26	Q - P	S - S	D - D	Z - Z
30	Q - P	S - S	D - D	Z - Z
34	Q - P	S - S	D - D	Z - Z
40	Q - P	S - S	D - D	Z - Z

Table showing standard flange and thread combinations available in stock

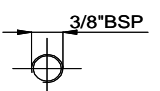
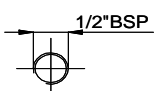
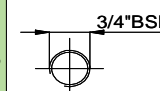
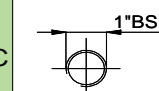
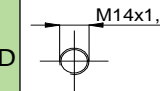
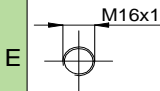
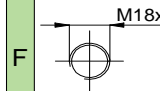
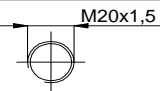
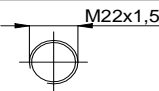
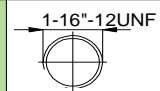
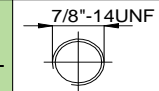
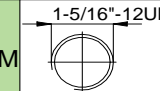
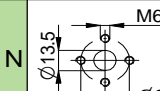
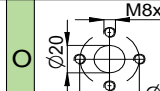
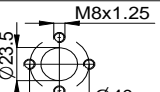
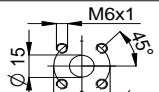
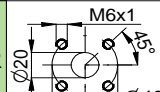
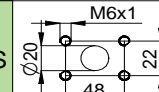
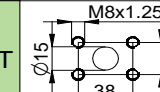
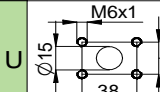
Body (threads/flanges)													
	A		B		C		D		E		F		G
	H		I		L		M		N		O		P
	Q		R		S		T		U		V	Closed Body Z	

reversible motor - series XV

XV-2M

STANDARD EUROPEAN MOTOR
ø36.5 FLANGE - TAPER SHAFT

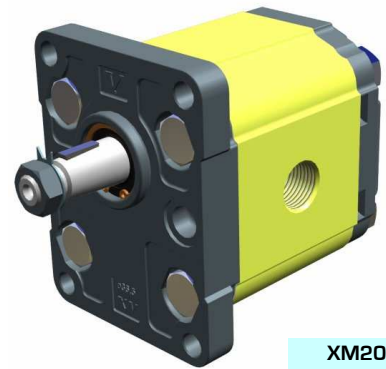

XM207

X 2 M 51 01 E C C E

Series	X	series XV
Group	2	group 2
Category	M	reversible motor
Displacement	51	17
Flange	01	Ø36.5 STANDARD EUROPEAN reversible rotation
Shaft	E	CO001 - Tapered 1:8 - ø17.4 - M12x1.5 - key thk.4
Body	IN	inlet - 3/4" GAS
	OUT	outlet - 3/4" GAS
Cover	E	with external drainage

Technical data table

TYPE	Displacement cm3/rev	Max. Pressure		CODE	
		P1 bar	P3 bar	External drainage	Internal drainage
XV-2M/04	4,20	260	300	X 2 M 41 01 E B B E	X 2 M 41 01 E B B F
XV-2M/06	6,00	260	300	X 2 M 43 01 E B B E	X 2 M 43 01 E B B F
XV-2M/09	8,40	260	300	X 2 M 45 01 E B B E	X 2 M 45 01 E B B F
XV-2M/11	10,80	260	300	X 2 M 47 01 E B B E	X 2 M 47 01 E B B F
XV-2M/14	14,40	250	290	X 2 M 49 01 E C C E	X 2 M 49 01 E C C F
XV-2M/17	16,80	230	270	X 2 M 51 01 E C C E	X 2 M 51 01 E C C F
XV-2M/19	19,20	210	250	X 2 M 53 01 E C C E	X 2 M 53 01 E C C F
XV-2M/22	22,80	200	240	X 2 M 55 01 E C C E	X 2 M 55 01 E C C F
XV-2M/26	26,20	170	210	X 2 M 57 01 E D D E	X 2 M 57 01 E D D F
XV-2M/30	30,00	160	200	X 2 M 59 01 E D D E	X 2 M 59 01 E D D F
XV-2M/34	34,20	150	190	X 2 M 61 01 E D D E	X 2 M 61 01 E D D F
XV-2M/40	39,60	140	180	X 2 M 63 01 E D D E	X 2 M 63 01 E D D F

P1) Max. working pressure - P3) Max. peak pressure

For heavy-duty applications, it is recommended to check the admissible torque of the shaft

Dimensions table

TYPE	Weight kg	A	B	C	D	D
		mm	mm	mm	IN	OUT
XV-2M/04	2,200	87,2	41,7	77,2	1/2" BSPP	1/2" BSPP
XV-2M/06	2,300	90,2	43,2	80,2	1/2" BSPP	1/2" BSPP
XV-2M/09	2,400	94,2	45,2	84,2	1/2" BSPP	1/2" BSPP
XV-2M/11	2,500	98,2	47,2	88,2	1/2" BSPP	1/2" BSPP
XV-2M/14	2,700	104,2	50,2	94,2	3/4" BSPP	3/4" BSPP
XV-2M/17	2,800	108,2	52,2	98,2	3/4" BSPP	3/4" BSPP
XV-2M/19	2,900	112,2	54,2	102,2	3/4" BSPP	3/4" BSPP
XV-2M/22	3,050	118,2	57,2	108,2	3/4" BSPP	3/4" BSPP
XV-2M/26	3,150	122,2	59,2	112,2	1" BSPP	1" BSPP
XV-2M/30	3,400	130,2	63,2	120,2	1" BSPP	1" BSPP
XV-2M/34	3,600	137,2	66,7	127,2	1" BSPP	1" BSPP
XV-2M/40	3,800	146,2	71,2	136,2	1" BSPP	1" BSPP

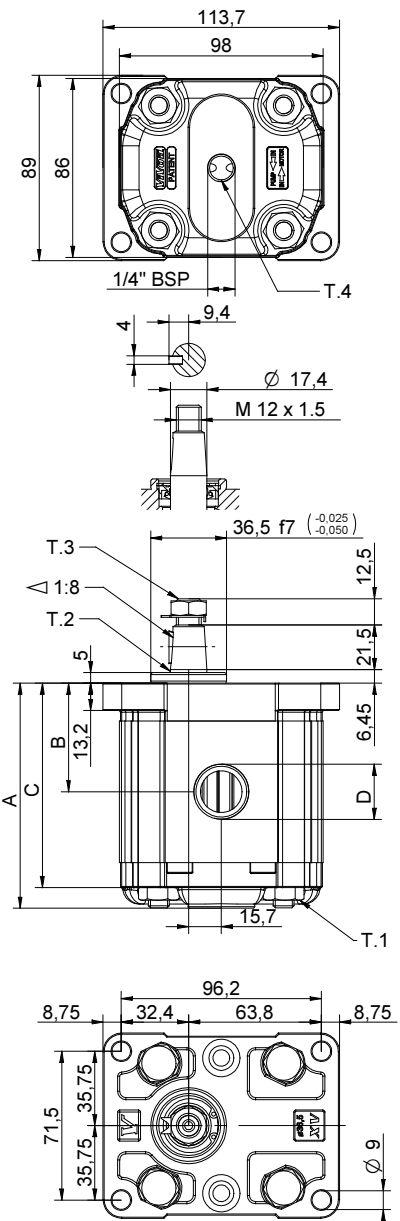

22/06/06 XZRS10 ECEE.dft

T.1 = 54÷58.9 [Nm] - screw tightening torque M10

T.3 = 40 [Nm] - torque wrench setting 19



T.2 = 233.2 [Nm] - admissible shaft torque (N.B. When choosing a shaft, always check the admissible torque).

T.4 = 0.3÷0.5 bar - max. drainage pressure

Table of variations

XV-2M

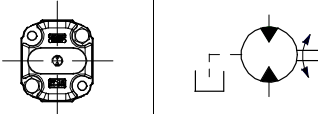
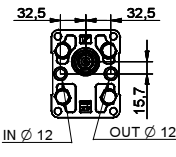
ø36.5 FLANGE

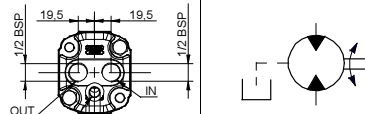
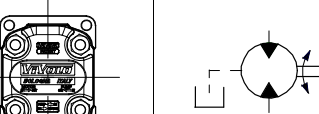
ø36.5 FLANGE		Shaft				Cover	
	01	CI001 - Parallel T.2 = 44.1 [Nm]	A	CI002 - Parallel T.2 = 67.5 [Nm]	B	 External drainage	E
		 IN Ø 12 OUT Ø 12	CO001 - Tapered T.2 = 233.2 [Nm]	E	CO002 - Tapered T.2 = 233.2 [Nm]		
 D Ø 12	05	SCF02 - Splined T.2 = 86.1 [Nm] m=1.6 Z=9 DIN 5482 - 17x14	G	SCF03 - Splined T.2 = 86.1 [Nm] m=1.6 Z=9 DIN 5482 - 17x14	H	 IN + OUT + external	K
		SCF04 - Splined T.2 = 67.1 [Nm] SAE J 498 9T 16/32 DP	I	SCF01 - Splined T.2 = 86.2 [Nm] m=1.6 Z=9 DIN 5482 - 17x14	L		
						 Flange drainage	P

Displacement	
TYPE	CODE
XV-2M/04	41
XV-2M/06	43
XV-2M/09	45
XV-2M/11	47
XV-2M/14	49
XV-2M/17	51
XV-2M/19	53
XV-2M/22	55
XV-2M/26	57
XV-2M/30	59
XV-2M/34	61
XV-2M/40	63

Displacement cm ³ /rev	Standard bodies			
	Standard threads			
4	O - O	R - R	B - B	Z - Z
6	O - O	R - R	B - B	Z - Z
9	O - O	R - R	B - B	Z - Z
11	O - O	R - R	B - B	Z - Z
14	P - P	R - R	C - C	Z - Z
17	P - P	R - R	C - C	Z - Z
19	P - P	R - R	C - C	Z - Z
22	P - P	R - R	C - C	Z - Z
26	Q - P	S - S	D - D	Z - Z
30	Q - P	S - S	D - D	Z - Z
34	Q - P	S - S	D - D	Z - Z
40	Q - P	S - S	D - D	Z - Z

Table showing standard flange and thread combinations available in stock

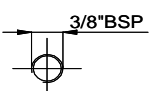
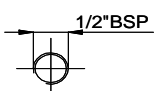
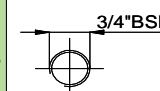
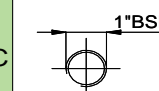
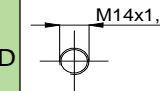
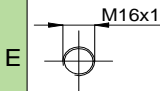
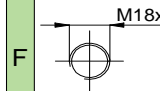
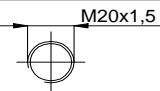
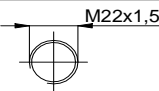
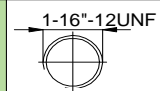
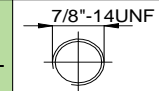
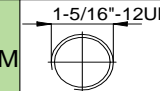
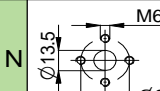
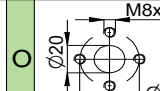
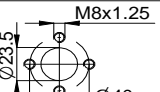
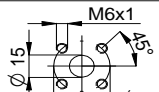
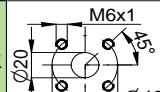
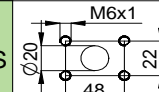
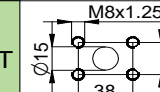
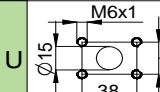
Body (threads/flanges)													
	A		B		C		D		E		F		G
	H		I		L		M		N		O		P
	Q		R		S		T		U		V	Closed Body	Z

reversible motor - series XV

XV-2M

BH TYPE MOTOR
ø50 BODY-SHAPED FLANGE - TAPER SHAFT

X 2 M 51 07 F R R E

Series	X	series XV
Group	2	group 2
Category	M	reversible motor
Displacement	51	17
Flange	07	Ø50 BH GERMAN STANDARDIZED reversible rotation
Shaft	F	CO002 - Tapered 1:5 - ø17.4 - M12x1.5 - key thk.3
Body	IN	inlet - Ø35 a 45° Ø15 M6
	OUT	outlet - Ø35 a 45° Ø15 M6
Cover	E	with external drainage

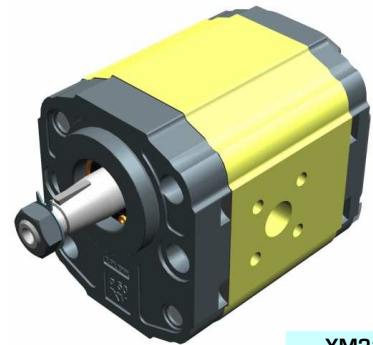

XM210

Technical data table

TYPE	Displacement cm3/rev	Max. Pressure		CODE	
		P1 bar	P3 bar	External drainage	Internal drainage
XV-2M/04	4,20	260	300	X 2 M 41 07 F R R E	X 2 M 41 07 F R R F
XV-2M/06	6,00	260	300	X 2 M 43 07 F R R E	X 2 M 43 07 F R R F
XV-2M/09	8,40	260	300	X 2 M 45 07 F R R E	X 2 M 45 07 F R R F
XV-2M/11	10,80	260	300	X 2 M 47 07 F R R E	X 2 M 47 07 F R R F
XV-2M/14	14,40	250	290	X 2 M 49 07 F R R E	X 2 M 49 07 F R R F
XV-2M/17	16,80	230	270	X 2 M 51 07 F R R E	X 2 M 51 07 F R R F
XV-2M/19	19,20	210	250	X 2 M 53 07 F R R E	X 2 M 53 07 F R R F
XV-2M/22	22,80	200	240	X 2 M 55 07 F R R E	X 2 M 55 07 F R R F
XV-2M/26	26,20	170	210	X 2 M 57 07 F S S E	X 2 M 57 07 F S S F
XV-2M/30	30,00	160	200	X 2 M 59 07 F S S E	X 2 M 59 07 F S S F
XV-2M/34	34,20	150	190	X 2 M 61 07 F S S E	X 2 M 61 07 F S S F
XV-2M/40	39,60	140	180	X 2 M 63 07 F S S E	X 2 M 63 07 F S S F

P1) Max. working pressure - P3) Max. peak pressure

For heavy-duty applications, it is recommended to check the admissible torque of the shaft

Dimensions table

TYPE	Weight kg	A	B	C	D	E	F	D	E	F
		mm	mm	mm	IN			OUT		
XV-2M/04	2,100	87,2	38,6	77,2	ø15	35	M6x1	ø15	35	M6x1
XV-2M/06	2,200	90,2	38,6	80,2	ø15	35	M6x1	ø15	35	M6x1
XV-2M/09	2,300	94,2	40,6	84,2	ø15	35	M6x1	ø15	35	M6x1
XV-2M/11	2,400	98,2	45,0	88,2	ø15	35	M6x1	ø15	35	M6x1
XV-2M/14	2,600	104,2	45,0	94,2	ø15	35	M6x1	ø15	35	M6x1
XV-2M/17	2,700	108,2	45,0	98,2	ø15	35	M6x1	ø15	35	M6x1
XV-2M/19	2,800	112,2	45,0	102,2	ø15	35	M6x1	ø15	35	M6x1
XV-2M/22	2,950	118,2	52,5	108,2	ø15	35	M6x1	ø15	35	M6x1
XV-2M/26	3,050	122,2	52,5	112,2	ø20	40	M6x1	ø20	40	M6x1
XV-2M/30	3,300	130,2	60,7	120,2	ø20	40	M6x1	ø20	40	M6x1
XV-2M/34	3,500	137,2	60,7	127,2	ø20	40	M6x1	ø20	40	M6x1
XV-2M/40	3,700	146,2	60,7	136,2	ø20	40	M6x1	ø20	40	M6x1

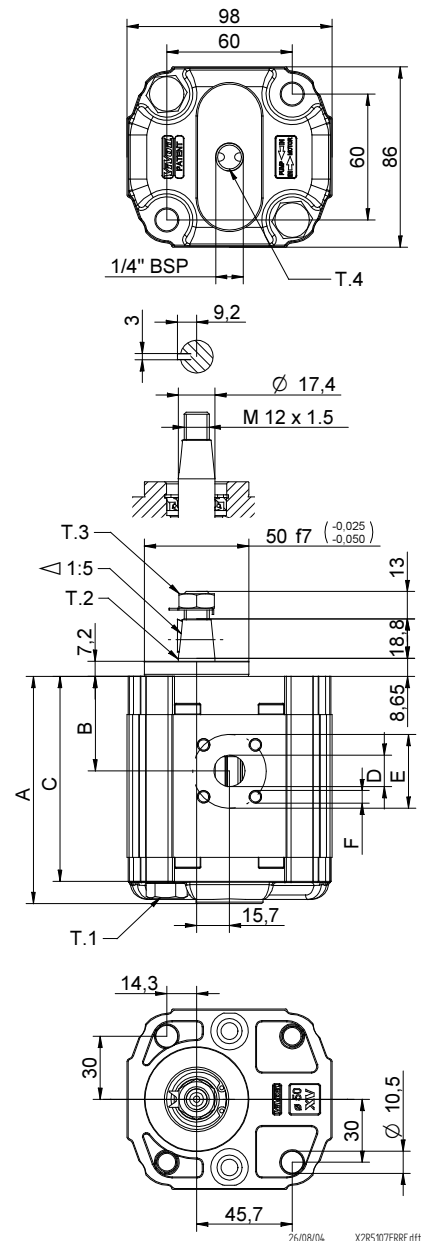

T.1 = 54÷58.9 [Nm] - screw tightening torque M10

T.3 = 40 [Nm] - torque wrench setting 19

T.2 = 233.2 [Nm] - admissible shaft torque (N.B. When choosing a shaft, always check the admissible torque).

T.4 = 0.3÷0.5 bar - max. drainage pressure

Table of variations

XV-2M

ø50 "BH" Body-Shaped FLANGE

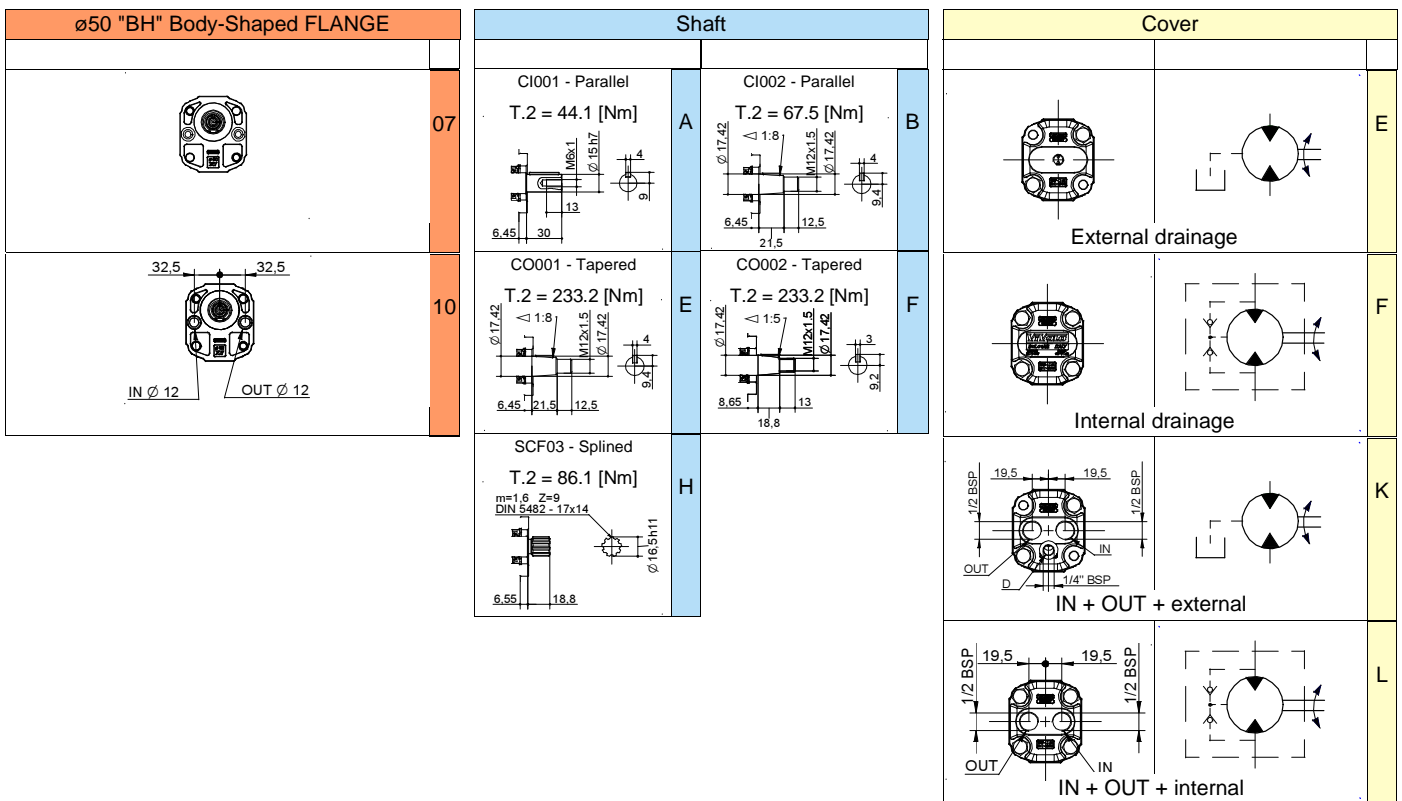

Displacement	
TYPE	CODE
XV-2M/04	41
XV-2M/06	43
XV-2M/09	45
XV-2M/11	47
XV-2M/14	49
XV-2M/17	51
XV-2M/19	53
XV-2M/22	55
XV-2M/26	57
XV-2M/30	59
XV-2M/34	61
XV-2M/40	63

Displacement cm3/rev	Standard bodies			
	Standard threads			
4	O - O	R - R	B - B	Z - Z
6	O - O	R - R	B - B	Z - Z
9	O - O	R - R	B - B	Z - Z
11	O - O	R - R	B - B	Z - Z
14	P - P	R - R	C - C	Z - Z
17	P - P	R - R	C - C	Z - Z
19	P - P	R - R	C - C	Z - Z
22	P - P	R - R	C - C	Z - Z
26	Q - P	S - S	D - D	Z - Z
30	Q - P	S - S	D - D	Z - Z
34	Q - P	S - S	D - D	Z - Z
40	Q - P	S - S	D - D	Z - Z

Table showing standard flange and thread combinations available in stock

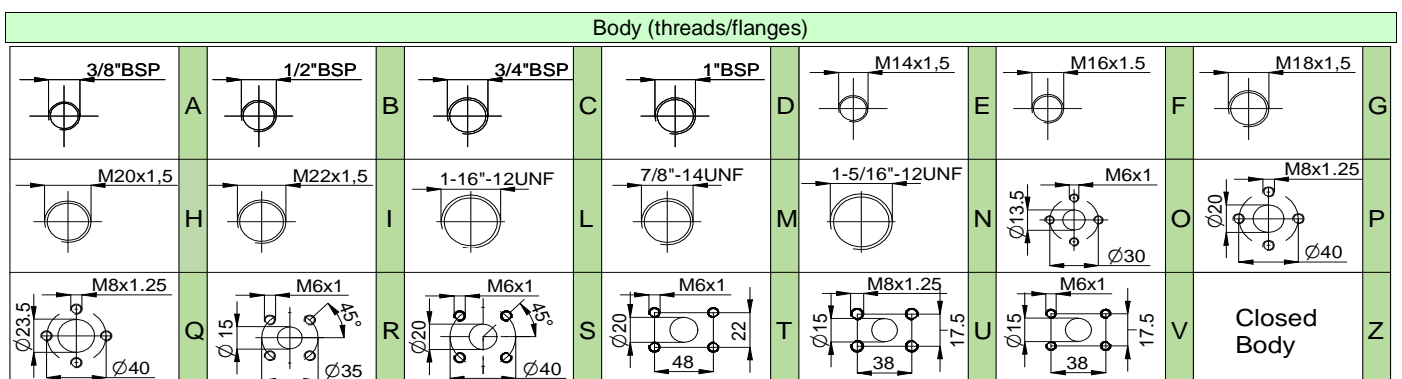

reversible motor - series XV

XV-2M

HY TYPE MOTOR
 ø50 BODY-SHAPED FLANGE - TAPER SHAFT

X 2 M 51 13 F R R E

Series	X	series XV
Group	2	group 2
Category	M	reversible motor
Displacement	51	17
Flange	13	Ø50 HY GERMAN STARDARDIZED reversible rotation
Shaft	F	CO002 - Tapered 1:5 - ø17.4 - M12x1.5 - key thk.3
Body	IN	inlet - Ø35 a 45° Ø15 M6
	OUT	outlet - Ø35 a 45° Ø15 M6
Cover	E	with external drainage

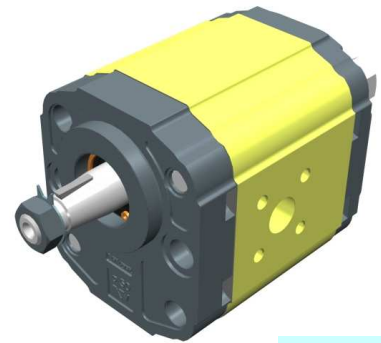

XM213

Technical data table

TYPE	Displacement cm3/rev	Max. Pressure		CODE	
		P1 bar	P3 bar	External drainage	Internal drainage
XV-2M/04	4,20	260	300	X 2 M 41 13 F R R E	X 2 M 41 13 F R R F
XV-2M/06	6,00	260	300	X 2 M 43 13 F R R E	X 2 M 43 13 F R R F
XV-2M/09	8,40	260	300	X 2 M 45 13 F R R E	X 2 M 45 13 F R R F
XV-2M/11	10,80	260	300	X 2 M 47 13 F R R E	X 2 M 47 13 F R R F
XV-2M/14	14,40	250	290	X 2 M 49 13 F R R E	X 2 M 49 13 F R R F
XV-2M/17	16,80	230	270	X 2 M 51 13 F R R E	X 2 M 51 13 F R R F
XV-2M/19	19,20	210	250	X 2 M 53 13 F R R E	X 2 M 53 13 F R R F
XV-2M/22	22,80	200	240	X 2 M 55 13 F R R E	X 2 M 55 13 F R R F
XV-2M/26	26,20	170	210	X 2 M 57 13 F S S E	X 2 M 57 13 F S S F
XV-2M/30	30,00	160	200	X 2 M 59 13 F S S E	X 2 M 59 13 F S S F
XV-2M/34	34,20	150	190	X 2 M 61 13 F S S E	X 2 M 61 13 F S S F
XV-2M/40	39,60	140	180	X 2 M 63 13 F S S E	X 2 M 63 13 F S S F

P1) Max. working pressure - P3) Max. peak pressure

For heavy-duty applications, it is recommended to check the admissible torque of the shaft

Dimensions table

TYPE	Weight kg	A	B	C	D	E	F	D	E	F
		mm	mm	mm	IN			OUT		
XV-2M/04	2,100	87,2	38,6	77,2	ø15	35	M6x1	ø15	35	M6x1
XV-2M/06	2,200	90,2	38,6	80,2	ø15	35	M6x1	ø15	35	M6x1
XV-2M/09	2,300	94,2	40,6	84,2	ø15	35	M6x1	ø15	35	M6x1
XV-2M/11	2,400	98,2	45,0	88,2	ø15	35	M6x1	ø15	35	M6x1
XV-2M/14	2,600	104,2	45,0	94,2	ø15	35	M6x1	ø15	35	M6x1
XV-2M/17	2,700	108,2	45,0	98,2	ø15	35	M6x1	ø15	35	M6x1
XV-2M/19	2,800	112,2	45,0	102,2	ø15	35	M6x1	ø15	35	M6x1
XV-2M/22	2,950	118,2	52,5	108,2	ø15	35	M6x1	ø15	35	M6x1
XV-2M/26	3,050	122,2	52,5	112,2	ø20	40	M6x1	ø20	40	M6x1
XV-2M/30	3,300	130,2	60,7	120,2	ø20	40	M6x1	ø20	40	M6x1
XV-2M/34	3,500	137,2	60,7	127,2	ø20	40	M6x1	ø20	40	M6x1
XV-2M/40	3,700	146,2	60,7	136,2	ø20	40	M6x1	ø20	40	M6x1

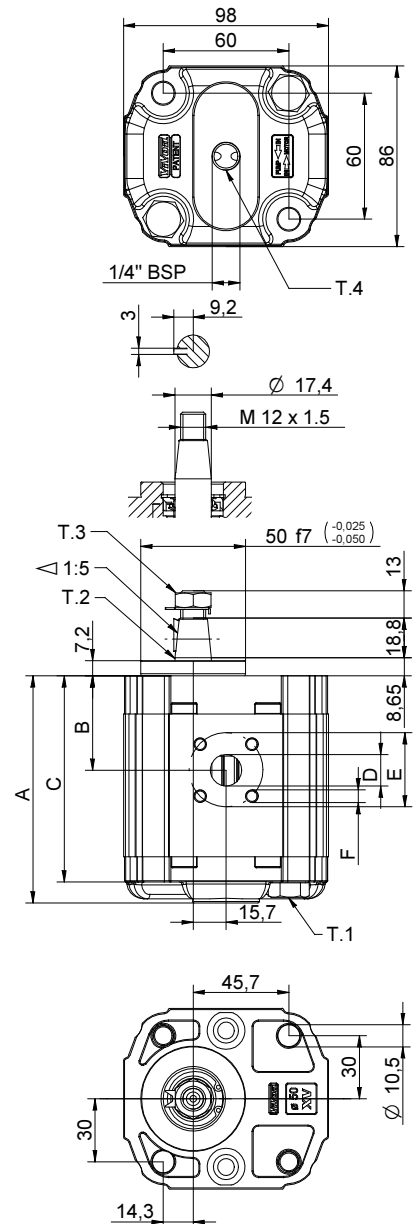

T.1 = 54÷58.9 [Nm] - screw tightening torque M10

T.3 = 40 [Nm] - torque wrench setting 19

T.2 = 233.2 [Nm] - admissible shaft torque (N.B. When choosing a shaft, always check the admissible torque).

T.4 = 0.3÷0.5 bar - max. drainage pressure

Table of variations

XV-2M

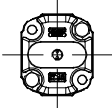
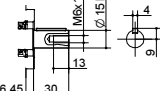
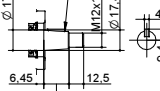
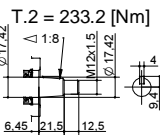
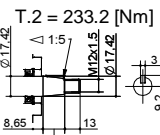
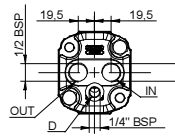
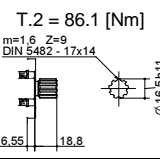
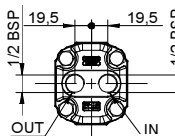

ø50 "HY" Body-Shaped FLANGE

ø50 "HY" Body-Shaped FLANGE		Shaft		Cover			
	13	CI001 - Parallel T.2 = 44.1 [Nm]	A	CI002 - Parallel T.2 = 67.5 [Nm]	B	 External drainage	E
				CO001 - Tapered T.2 = 233.2 [Nm]	E		
		SCF03 - Splined T.2 = 86.1 [Nm]	H				 IN + OUT + external
					 IN + OUT + internal	L	

Displacement	
TYPE	CODE
XV-2M/04	41
XV-2M/06	43
XV-2M/09	45
XV-2M/11	47
XV-2M/14	49
XV-2M/17	51
XV-2M/19	53
XV-2M/22	55
XV-2M/26	57
XV-2M/30	59
XV-2M/34	61
XV-2M/40	63

Standard bodies					
Displacement cm3/rev	Standard threads				
	4	O - O	R - R	B - B	Z - Z
6	O - O	R - R	B - B	Z - Z	
9	O - O	R - R	B - B	Z - Z	
11	O - O	R - R	B - B	Z - Z	
14	P - P	R - R	C - C	Z - Z	
17	P - P	R - R	C - C	Z - Z	
19	P - P	R - R	C - C	Z - Z	
22	P - P	R - R	C - C	Z - Z	
26	Q - P	S - S	D - D	Z - Z	
30	Q - P	S - S	D - D	Z - Z	
34	Q - P	S - S	D - D	Z - Z	
40	Q - P	S - S	D - D	Z - Z	

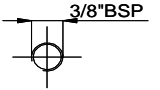
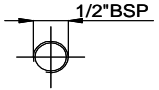
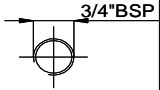
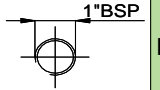
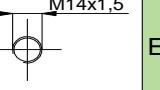
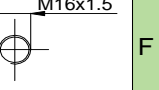
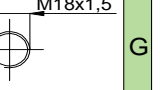
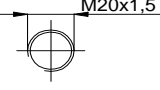
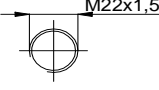
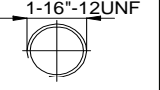
Table showing standard flange and thread combinations available in stock

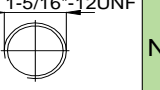
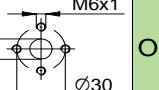
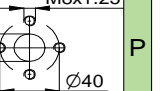
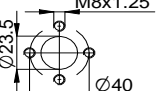
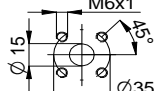
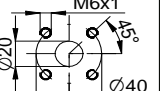
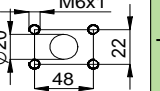
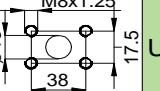
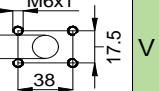
Body (threads/flanges)													
	A		B		C		D		E		F		G
	H		I		L		M		N		O		P
	Q		R		S		T		U		V	Closed Body Z	

reversible motor - series XV

XV-2M

STANDARD GERMAN "BH" TYPE MOTOR
 ø52 BODY-SHAPED FLANGE - MILLED SHANK

X 2 M 51 19 C R R E

Series	X	series XV
Group	2	group 2
Category	M	reversible motor
Displacement	51	17
Flange	19	Ø52 GERMAN STANDARDIZED reversible rotation (with OR)
Shaft	C	CF001 - Milled shank ø15 - thk.8 ("BH" Standard German)
Body	IN	inlet - Ø35 a 45° Ø15 M6
	OUT	outlet - Ø35 a 45° Ø15 M6
Cover	E	with external drainage

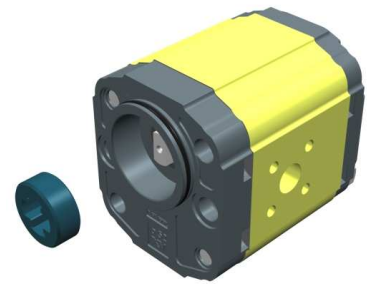

XM216

Technical data table

TYPE	Displacement cm3/rev	Max. Pressure		CODE	
		P1 bar	P3 bar	External drainage	Internal drainage
XV-2M/04	4,20	260	300	X 2 M 41 19 C R R E	X 2 M 41 19 C R R F
XV-2M/06	6,00	260	300	X 2 M 43 19 C R R E	X 2 M 43 19 C R R F
XV-2M/09	8,40	260	300	X 2 M 45 19 C R R E	X 2 M 45 19 C R R F
XV-2M/11	10,80	260	300	X 2 M 47 19 C R R E	X 2 M 47 19 C R R F
XV-2M/14	14,40	250	290	X 2 M 49 19 C R R E	X 2 M 49 19 C R R F
XV-2M/17	16,80	230	270	X 2 M 51 19 C R R E	X 2 M 51 19 C R R F
XV-2M/19	19,20	210	250	X 2 M 53 19 C R R E	X 2 M 53 19 C R R F
XV-2M/22	22,80	200	240	X 2 M 55 19 C R R E	X 2 M 55 19 C R R F
XV-2M/26	26,20	170	210	X 2 M 57 19 C S S E	X 2 M 57 19 C S S F
XV-2M/30	30,00	160	200	X 2 M 59 19 C S S E	X 2 M 59 19 C S S F
XV-2M/34	34,20	150	190	X 2 M 61 19 C S S E	X 2 M 61 19 C S S F
XV-2M/40	39,60	140	180	X 2 M 63 19 C S S E	X 2 M 63 19 C S S F

P1) Max. working pressure - P3) Max. peak pressure

For heavy-duty applications, it is recommended to check the admissible torque of the shaft

Dimensions table

TYPE	Weight kg	A	B	C	D	E	F	D	E	F
		mm	mm	mm	IN			OUT		
XV-2M/04	2,100	87,2	38,6	77,2	ø15	35	M6x1	ø15	35	M6x1
XV-2M/06	2,200	90,2	38,6	80,2	ø15	35	M6x1	ø15	35	M6x1
XV-2M/09	2,300	94,2	40,6	84,2	ø15	35	M6x1	ø15	35	M6x1
XV-2M/11	2,400	98,2	45,0	88,2	ø15	35	M6x1	ø15	35	M6x1
XV-2M/14	2,600	104,2	45,0	94,2	ø15	35	M6x1	ø15	35	M6x1
XV-2M/17	2,700	108,2	45,0	98,2	ø15	35	M6x1	ø15	35	M6x1
XV-2M/19	2,800	112,2	45,0	102,2	ø15	35	M6x1	ø15	35	M6x1
XV-2M/22	2,950	118,2	52,5	108,2	ø15	35	M6x1	ø15	35	M6x1
XV-2M/26	3,050	122,2	52,5	112,2	ø20	40	M6x1	ø20	40	M6x1
XV-2M/30	3,300	130,2	60,7	120,2	ø20	40	M6x1	ø20	40	M6x1
XV-2M/34	3,500	137,2	60,7	127,2	ø20	40	M6x1	ø20	40	M6x1
XV-2M/40	3,700	146,2	60,7	136,2	ø20	40	M6x1	ø20	40	M6x1

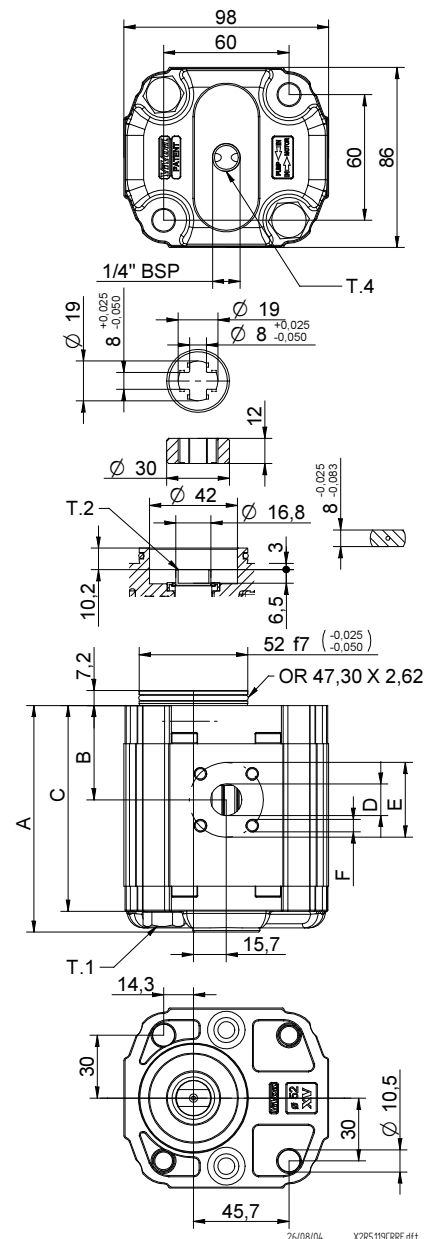

T.1 = 54÷58.9 [Nm] - screw tightening torque M10

T.2 = 60.5 [Nm] - admissible shaft torque (N.B. When choosing a shaft, always check the admissible torque).

T.4 = 0.3÷0.5 bar - max. drainage pressure

Table of variations

XV-2M

Standard German ø52 "BH" FLANGE

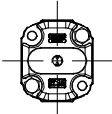
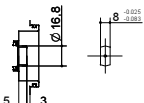
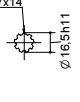
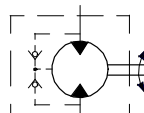
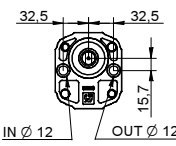
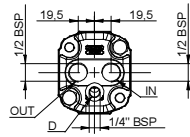
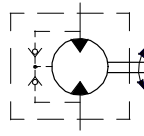
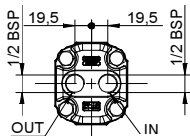
Standard German ø52 "BH" FLANGE		Shaft		Cover			
	19	CF001 - Milled shank T.2 = 60.5 [Nm]	C	SCF05 - Splined T.2 = 86.2 [Nm] m=1.6 Z=9 DIN 5462 - 17x14	K	 External drainage	E
			22	SCF01 - Splined T.2 = 86.2 [Nm] m=1.6 Z=9 DIN 5462 - 17x14	L		 Internal drainage
	 IN + OUT + external	 IN + OUT + internal		K	L	 IN + OUT + external	L

Displacement	
TYPE	CODE
XV-2M/04	41
XV-2M/06	43
XV-2M/09	45
XV-2M/11	47
XV-2M/14	49
XV-2M/17	51
XV-2M/19	53
XV-2M/22	55
XV-2M/26	57
XV-2M/30	59
XV-2M/34	61
XV-2M/40	63

Standard bodies					
Displacement cm3/rev	Standard threads				
	4	O - O	R - R	B - B	Z - Z
6	O - O	R - R	B - B	Z - Z	
9	O - O	R - R	B - B	Z - Z	
11	O - O	R - R	B - B	Z - Z	
14	P - P	R - R	C - C	Z - Z	
17	P - P	R - R	C - C	Z - Z	
19	P - P	R - R	C - C	Z - Z	
22	P - P	R - R	C - C	Z - Z	
26	Q - P	S - S	D - D	Z - Z	
30	Q - P	S - S	D - D	Z - Z	
34	Q - P	S - S	D - D	Z - Z	
40	Q - P	S - S	D - D	Z - Z	

Table showing standard flange and thread combinations available in stock

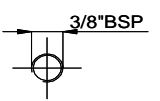
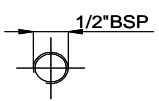
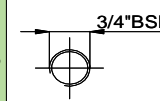
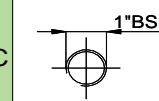
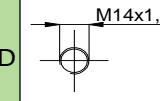
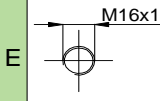
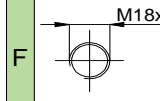
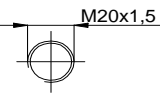
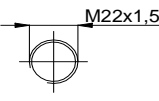
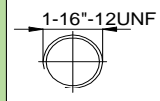
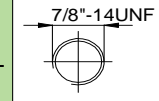
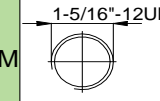
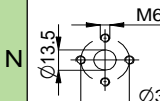
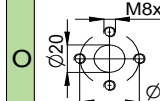
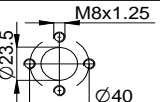
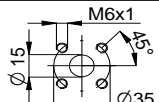
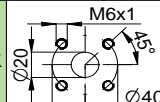
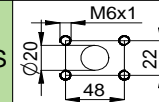
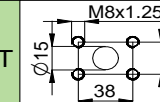
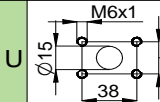
Body (threads/flanges)													
	A		B		C		D		E		F		G
	H		I		L		M		N		O		P
	Q		R		S		T		U		V	Closed Body	Z

reversible motor - series XV

XV-2M

STANDARD GERMAN MOTOR
ø80 FLANGE - TAPER SHAFT

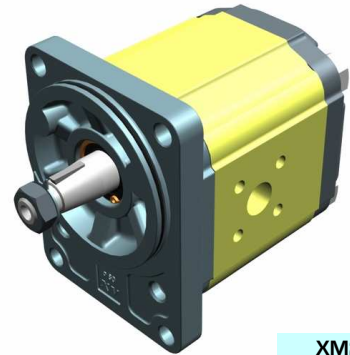

XM217

X 2 M 51 25 F R R E

Series	X	series XV
Group	2	group 2
Category	M	reversible motor
Displacement	51	17
Flange	25	Ø80 GERMAN STANDARDIZED reversible rotation (with OR)
Shaft	F	CO002 - Tapered 1:5 - ø17.4 - M12x1.5 - key thk.3
Body	IN	inlet - Ø35 a 45° Ø15 M6
	OUT	outlet - Ø35 a 45° Ø15 M6
Cover	E	with external drainage

Technical data table

TYPE	Displacement cm3/rev	Max. Pressure		CODE	
		P1 bar	P3 bar	External drainage	Internal drainage
XV-2M/04	4,20	260	300	X 2 M 41 25 F R R E	X 2 M 41 25 F R R F
XV-2M/06	6,00	260	300	X 2 M 43 25 F R R E	X 2 M 43 25 F R R F
XV-2M/09	8,40	260	300	X 2 M 45 25 F R R E	X 2 M 45 25 F R R F
XV-2M/11	10,80	260	300	X 2 M 47 25 F R R E	X 2 M 47 25 F R R F
XV-2M/14	14,40	250	290	X 2 M 49 25 F R R E	X 2 M 49 25 F R R F
XV-2M/17	16,80	230	270	X 2 M 51 25 F R R E	X 2 M 51 25 F R R F
XV-2M/19	19,20	210	250	X 2 M 53 25 F R R E	X 2 M 53 25 F R R F
XV-2M/22	22,80	200	240	X 2 M 55 25 F R R E	X 2 M 55 25 F R R F
XV-2M/26	26,20	170	210	X 2 M 57 25 F S S E	X 2 M 57 25 F S S F
XV-2M/30	30,00	160	200	X 2 M 59 25 F S S E	X 2 M 59 25 F S S F
XV-2M/34	34,20	150	190	X 2 M 61 25 F S S E	X 2 M 61 25 F S S F
XV-2M/40	39,60	140	180	X 2 M 63 25 F S S E	X 2 M 63 25 F S S F

P1) Max. working pressure - P3) Max. peak pressure

For heavy-duty applications, it is recommended to check the admissible torque of the shaft

Dimensions table

TYPE	Weight kg	A	B	C	D	E	F	D	E	F
		mm	mm	mm	IN			OUT		
XV-2M/04	2,330	89,7	41,1	79,7	ø15	35	M6x1	ø15	35	M6x1
XV-2M/06	2,430	92,7	41,1	82,7	ø15	35	M6x1	ø15	35	M6x1
XV-2M/09	2,530	96,7	43,1	86,7	ø15	35	M6x1	ø15	35	M6x1
XV-2M/11	2,630	100,7	47,5	90,7	ø15	35	M6x1	ø15	35	M6x1
XV-2M/14	2,730	106,7	47,5	96,7	ø15	35	M6x1	ø15	35	M6x1
XV-2M/17	2,830	110,7	47,5	100,7	ø15	35	M6x1	ø15	35	M6x1
XV-2M/19	2,930	114,7	47,5	104,7	ø15	35	M6x1	ø15	35	M6x1
XV-2M/22	3,180	120,7	55,0	110,7	ø15	35	M6x1	ø15	35	M6x1
XV-2M/26	3,280	124,7	55,0	114,7	ø20	40	M6x1	ø20	40	M6x1
XV-2M/30	3,530	132,7	63,2	122,7	ø20	40	M6x1	ø20	40	M6x1
XV-2M/34	3,730	139,7	63,2	129,7	ø20	40	M6x1	ø20	40	M6x1
XV-2M/40	3,930	148,7	63,2	138,7	ø20	40	M6x1	ø20	40	M6x1

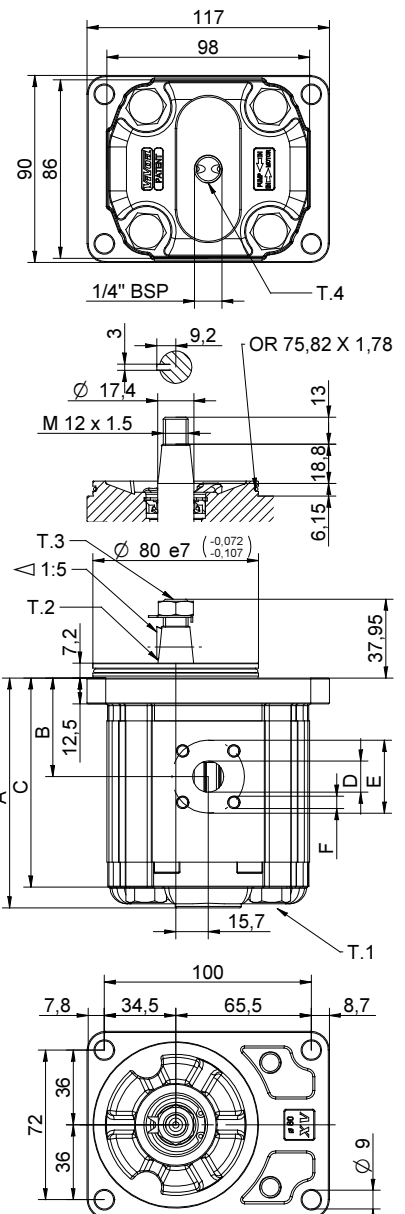

26/08/04 X2R5125FRRE.dft

T.1 = 54÷58.9 [Nm] - screw tightening torque M10

T.3 = 40 [Nm] - torque wrench setting 19

T.2 = 233.2 [Nm] - admissible shaft torque (N.B. When choosing a shaft, always check the admissible torque).

T.4 = 0.3÷0.5 bar - max. drainage pressure

Table of variations

XV-2M

ø80 FLANGE

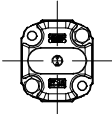
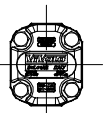
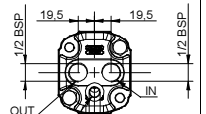
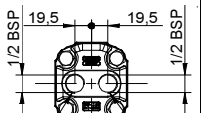
ø80 FLANGE		Shaft		Cover			
	25	CI001 - Parallel T.2 = 44.1 [Nm]	A	CI002 - Parallel T.2 = 67.5 [Nm]	B	 External drainage	E
		CO001 - Tapered T.2 = 233.2 [Nm]	E	CO002 - Tapered T.2 = 233.2 [Nm]	F	 Internal drainage	F
		SCF03 - Splined T.2 = 86.1 [Nm]	H			 IN + OUT + external	K
				 IN + OUT + internal	L	L	

Displacement	
TYPE	CODE
XV-2M/04	41
XV-2M/06	43
XV-2M/09	45
XV-2M/11	47
XV-2M/14	49
XV-2M/17	51
XV-2M/19	53
XV-2M/22	55
XV-2M/26	57
XV-2M/30	59
XV-2M/34	61
XV-2M/40	63

Standard bodies				
Displacement cm3/rev	Standard threads			
	4	O - O	R - R	B - B
6	O - O	R - R	B - B	Z - Z
9	O - O	R - R	B - B	Z - Z
11	O - O	R - R	B - B	Z - Z
14	P - P	R - R	C - C	Z - Z
17	P - P	R - R	C - C	Z - Z
19	P - P	R - R	C - C	Z - Z
22	P - P	R - R	C - C	Z - Z
26	Q - P	S - S	D - D	Z - Z
30	Q - P	S - S	D - D	Z - Z
34	Q - P	S - S	D - D	Z - Z
40	Q - P	S - S	D - D	Z - Z

Table showing standard flange and thread combinations available in stock

Body (threads/flanges)													
	A		B		C		D		E		F		G
	H		I		L		M		N		O		P
	Q		R		S		T		U		V	Closed Body	Z

reversible motor - series XV

XV-2M

SAE A TYPE MOTOR
 ø82.5 FLANGE - SPLINED SHAFT

X 2 M 51 31 I R R E

Series	X	series XV
Group	2	group 2
Category	M	reversible motor
Displacement	51	17
Flange	31	Ø82.5 SAE A reversible rotation (with OR)
Shaft	I	SCF04 - Splined ø15.456 z=9, H=22.5 - SAE J498 9T 16/32DP
Body	IN	inlet - Ø35 a 45° Ø15 M6
	OUT	outlet - Ø35 a 45° Ø15 M6
Cover	E	with external drainage

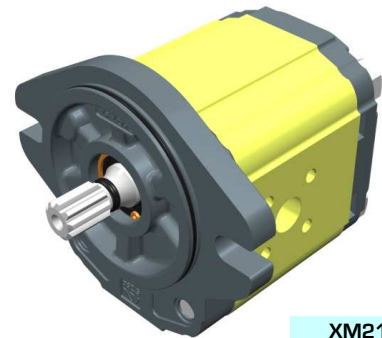

XM219

Technical data table

TYPE	Displacement cm3/rev	Max. Pressure		CODE																	
		P1 bar	P3 bar	External drainage				Internal drainage													
XV-2M/04	4,20	260	300	X	2	M	41	31	I	R	R	E	X	2	M	41	31	I	R	R	F
XV-2M/06	6,00	260	300	X	2	M	43	31	I	R	R	E	X	2	M	43	31	I	R	R	F
XV-2M/09	8,40	260	300	X	2	M	45	31	I	R	R	E	X	2	M	45	31	I	R	R	F
XV-2M/11	10,80	260	300	X	2	M	47	31	I	R	R	E	X	2	M	47	31	I	R	R	F
XV-2M/14	14,40	250	290	X	2	M	49	31	I	R	R	E	X	2	M	49	31	I	R	R	F
XV-2M/17	16,80	230	270	X	2	M	51	31	I	R	R	E	X	2	M	51	31	I	R	R	F
XV-2M/19	19,20	210	250	X	2	M	53	31	I	R	R	E	X	2	M	53	31	I	R	R	F
XV-2M/22	22,80	200	240	X	2	M	55	31	I	R	R	E	X	2	M	55	31	I	R	R	F
XV-2M/26	26,20	170	210	X	2	M	57	31	I	S	S	E	X	2	M	57	31	I	S	S	F
XV-2M/30	30,00	160	200	X	2	M	59	31	I	S	S	E	X	2	M	59	31	I	S	S	F
XV-2M/34	34,20	150	190	X	2	M	61	31	I	S	S	E	X	2	M	61	31	I	S	S	F
XV-2M/40	39,60	140	180	X	2	M	63	31	I	S	S	E	X	2	M	63	31	I	S	S	F

P1) Max. working pressure - P3) Max. peak pressure

For heavy-duty applications, it is recommended to check the admissible torque of the shaft

Dimensions table

TYPE	Weight kg	A	B	C	D	E	F	D	E	F
		mm	mm	mm	IN			OUT		
XV-2M/04	2,280	88,0	39,4	78,0	ø15	35	M6x1	ø15	35	M6x1
XV-2M/06	2,380	91,0	39,4	81,0	ø15	35	M6x1	ø15	35	M6x1
XV-2M/09	2,480	95,0	41,4	85,0	ø15	35	M6x1	ø15	35	M6x1
XV-2M/11	2,580	99,0	45,8	89,0	ø15	35	M6x1	ø15	35	M6x1
XV-2M/14	2,780	105,0	45,8	95,0	ø15	35	M6x1	ø15	35	M6x1
XV-2M/17	2,880	109,0	45,8	99,0	ø15	35	M6x1	ø15	35	M6x1
XV-2M/19	2,980	113,0	45,8	103,0	ø15	35	M6x1	ø15	35	M6x1
XV-2M/22	3,130	119,0	53,3	109,0	ø15	35	M6x1	ø15	35	M6x1
XV-2M/26	3,230	123,0	53,3	113,0	ø20	40	M6x1	ø20	40	M6x1
XV-2M/30	3,480	131,0	61,5	121,0	ø20	40	M6x1	ø20	40	M6x1
XV-2M/34	3,680	138,0	61,5	128,0	ø20	40	M6x1	ø20	40	M6x1
XV-2M/40	3,880	147,0	61,5	137,0	ø20	40	M6x1	ø20	40	M6x1

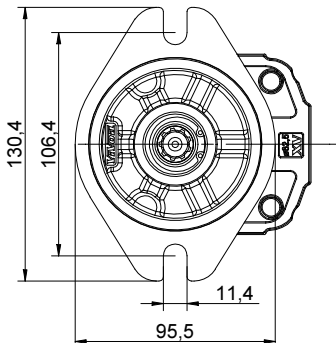
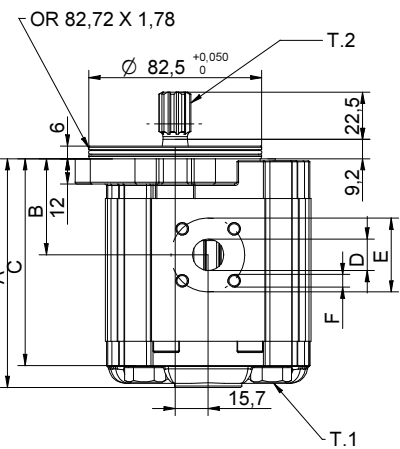
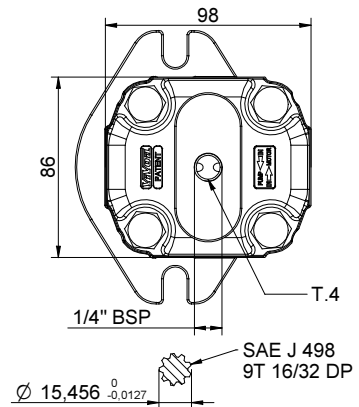

26/08/04 XZRS1310RRE.dft

T.1 = 54÷58.9 [Nm] - screw tightening torque M10



T.2 = 67.1 [Nm] - admissible shaft torque (N.B. When choosing a shaft, always check the admissible torque).

T.4 = 0.3÷0.5 bar - max. drainage pressure

Table of variations

XV-2M

ø82.5 FLANGE "SAE A"

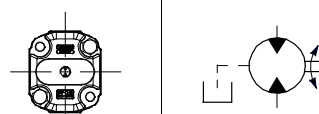
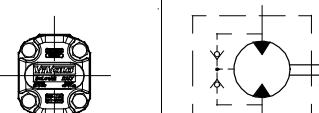
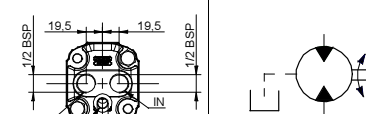
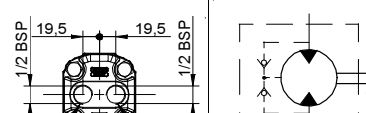
ø82.5 FLANGE "SAE A"		Shaft		Cover		
	31	CI001 - Parallel T.2 = 44.1 [Nm]	A	CI002 - Parallel T.2 = 67.5 [Nm]	B	
		 Without OR	32	CO001 - Tapered T.2 = 233.2 [Nm]	E	CO002 - Tapered T.2 = 233.2 [Nm]
		SCF04 - Splined T.2 = 67.1 [Nm]		I	 External drainage	
				 Internal drainage		F
				 IN + OUT + external		K
				 IN + OUT + internal		L

Displacement	
TYPE	CODE
XV-2M/04	41
XV-2M/06	43
XV-2M/09	45
XV-2M/11	47
XV-2M/14	49
XV-2M/17	51
XV-2M/19	53
XV-2M/22	55
XV-2M/26	57
XV-2M/30	59
XV-2M/34	61
XV-2M/40	63

Standard bodies					
Displacement cm ³ /rev	Standard threads				
	4	O - O	R - R	B - B	Z - Z
6	O - O	R - R	B - B	Z - Z	
9	O - O	R - R	B - B	Z - Z	
11	O - O	R - R	B - B	Z - Z	
14	P - P	R - R	C - C	Z - Z	
17	P - P	R - R	C - C	Z - Z	
19	P - P	R - R	C - C	Z - Z	
22	P - P	R - R	C - C	Z - Z	
26	Q - P	S - S	D - D	Z - Z	
30	Q - P	S - S	D - D	Z - Z	
34	Q - P	S - S	D - D	Z - Z	
40	Q - P	S - S	D - D	Z - Z	

Table showing standard flange and thread combinations available in stock

Body (threads/flanges)													
	A		B		C		D		E		F		G
	H		I		L		M		N		O		P
	Q		R		S		T		U		V	Closed Body Z	

reversible motor - series XV

XV-3M

**STANDARD EUROPEAN MOTOR
ø50.8 FLANGE - TAPER SHAFT**

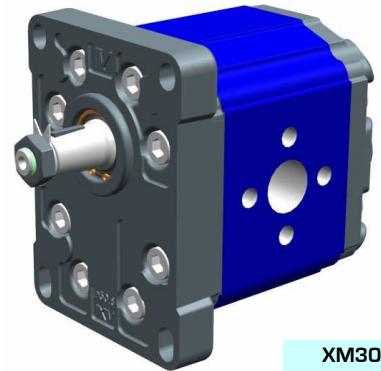

XM301

X 3 M 78 01 A B B E

Series	X	series XV
Group	3	group 3
Category	M	reversible motor
Displacement	78	38
Flange	01	ø50.8 reversible rotation
Shaft	A	CO001 - Tapered 1:8 - ø22 - key thk.4
Body	IN	inlet - ø51 ø27 M10
	OUT	outlet - ø51 ø27 M10
Cover	E	with external drainage

Technical data table																					
TYPE	Displacement cm3/rev	Max. Pressure		CODE																	
		P1 bar	P3 bar	External drainage			Internal drainage														
XV-3M/15	14,89	250	270	X	3	M	66	01	A	A	A	E	X	3	M	66	01	A	A	A	F
XV-3M/18	17,37	250	270	X	3	M	68	01	A	A	A	E	X	3	M	68	01	A	A	A	F
XV-3M/21	21,10	250	270	X	3	M	70	01	A	A	A	E	X	3	M	70	01	A	A	A	F
XV-3M/27	26,97	250	270	X	3	M	72	01	A	A	A	E	X	3	M	72	01	A	A	A	F
XV-3M/32	32,27	250	270	X	3	M	74	01	A	B	B	E	X	3	M	74	01	A	B	B	F
XV-3M/38	38,47	250	270	X	3	M	78	01	A	B	B	E	X	3	M	78	01	A	B	B	F
XV-3M/43	43,44	250	270	X	3	M	79	01	A	B	B	E	X	3	M	79	01	A	B	B	F
XV-3M/47	47,16	230	250	X	3	M	80	01	A	B	B	E	X	3	M	80	01	A	B	B	F
XV-3M/51	50,88	230	250	X	3	M	81	01	A	B	B	E	X	3	M	81	01	A	B	B	F
XV-3M/54	54,60	230	250	X	3	M	82	01	A	B	B	E	X	3	M	82	01	A	B	B	F
XV-3M/61	60,81	230	250	X	3	M	83	01	A	C	C	E	X	3	M	83	01	A	C	C	F
XV-3M/64	64,53	210	230	X	3	M	85	01	A	C	C	E	X	3	M	85	01	A	C	C	F
XV-3M/70	70,74	200	220	X	3	M	86	01	A	C	C	E	X	3	M	86	01	A	C	C	F
XV-3M/74	74,46	180	200	X	3	M	87	01	A	C	C	E	X	3	M	87	01	A	C	C	F
XV-3M/90	86,87	150	170	X	3	M	89	01	A	C	C	E	X	3	M	89	01	A	C	C	F

P1) Max. working pressure - P3) Max. peak pressure

For heavy-duty applications, it is recommended to check the admissible torque of the shaft

Dimensions table									
TYPE	Weight	A	B	D	E	F	D	E	F
	kg	mm	mm	IN			OUT		
XV-3M/15	7,010	122,0	61,0	ø20	40	M8	ø20	40	M8
XV-3M/18	7,070	124,0	62,0	ø20	40	M8	ø20	40	M8
XV-3M/21	7,150	127,0	63,5	ø20	40	M8	ø20	40	M8
XV-3M/27	7,250	131,0	65,5	ø20	40	M8	ø20	40	M8
XV-3M/32	7,390	136,0	68,0	ø27	51	M10	ø27	51	M10
XV-3M/38	7,520	141,0	70,5	ø27	51	M10	ø27	51	M10
XV-3M/43	7,630	145,0	72,5	ø27	51	M10	ø27	51	M10
XV-3M/47	7,710	148,0	74,0	ø27	51	M10	ø27	51	M10
XV-3M/51	7,790	151,0	75,5	ø27	51	M10	ø27	51	M10
XV-3M/54	7,870	154,0	77,0	ø27	51	M10	ø27	51	M10
XV-3M/61	8,010	159,0	79,5	ø36	62	M10	ø36	62	M10
XV-3M/64	8,090	162,0	81,0	ø36	62	M10	ø36	62	M10
XV-3M/70	8,220	167,0	83,5	ø36	62	M10	ø36	62	M10
XV-3M/74	8,300	170,0	85,0	ø36	62	M10	ø36	62	M10
XV-3M/90	8,570	180,0	90,0	ø36	62	M10	ø36	62	M10

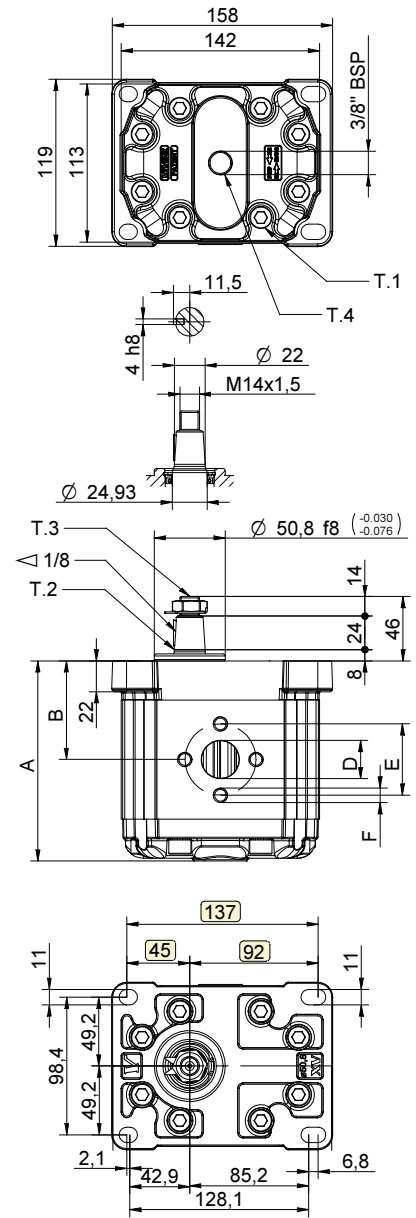

T.1 = 60÷65 [Nm] - screw tightening torque M10

T.3 = 75 [Nm] - torque wrench setting 22



T.2 = 482 [Nm] - admissible shaft torque (N.B. When choosing a shaft, always check the admissible torque).

T.4 = 0.3÷0.5 bar - max. drainage pressure

Table of variations

XV-3M

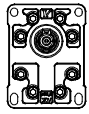
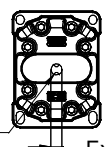
ø50.8 FLANGE

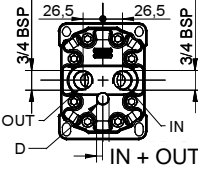
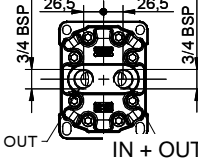
ø50.8 FLANGE		Shaft				Cover	
	01	CO001 - Tapered T.2 = 482 [Nm]	A	CI001 - Parallel T.2 = 181 [Nm]	B	 External drainage	E
		SCF03 - Splined T.2 = 223 [Nm]	C	CI004 - Parallel T.2 = 180 [Nm]	H		 Internal drainage
		SCF04 - Splined T.2 = 264 [Nm]	I			 IN + OUT + external	
							 IN + OUT + internal

Displacement	
TYPE	CODE
XV-3M/15	66
XV-3M/18	68
XV-3M/21	70
XV-3M/27	72
XV-3M/32	74
XV-3M/38	78
XV-3M/43	79
XV-3M/47	80
XV-3M/51	81
XV-3M/54	82
XV-3M/61	83
XV-3M/64	85
XV-3M/70	86
XV-3M/74	87
XV-3M/90	89

Standard bodies				
Displacement cm3/rev	Standard threads			
	15	A - A	D - D	H - H
18	A - A	D - D	H - H	
21	A - A	D - D	H - H	
27	A - A	E - E	H - H	
32	B - B	E - E	H - H	
38	B - B	E - E	H - H	
43	B - B	E - E	H - H	
47	B - B	E - E	H - H	
51	B - B	E - E	H - H	
54	B - B	E - E	H - H	
61	C - C	F - F		
64	C - C	F - F		
70	C - C	F - F		
74	C - C	F - F		
90	C - C	F - F		

Table showing standard flange and thread combinations available in stock

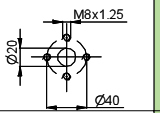
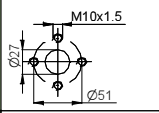
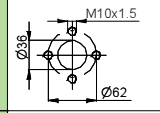
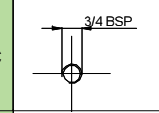
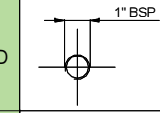
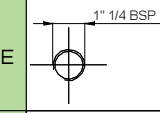
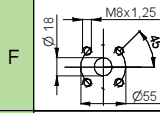
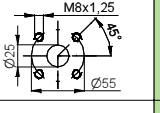
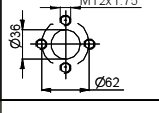
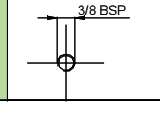
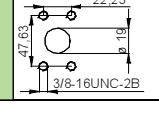
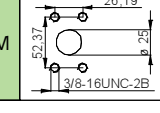
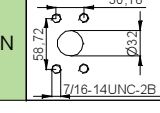
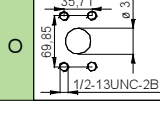
Body (threads/flanges)													
	A		B		C		D		E		F		G
	H		I		L		M		N		O		P
Closed Body	Z												

reversible motor - series XV

XV-3M

STANDARD EUROPEAN MOTOR
ø50.8 FLANGE - TAPER SHAFT

X 3 M 78 01 A E E E

Series	X	series XV
Group	3	group 3
Category	M	reversible motor
Displacement	78	38
Flange	01	ø50.8 reversible rotation
Shaft	A	CO001 - Tapered 1:8 - ø22 - key thk.4
Body	IN	inlet - 1" BSP
	OUT	outlet - 1" BSP
Cover	E	with external drainage

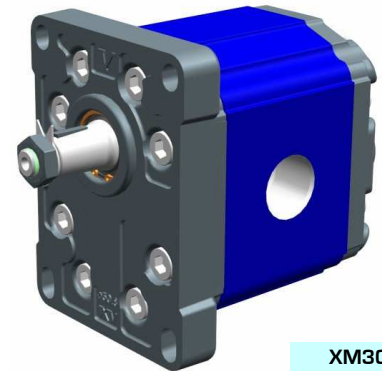

XM302

Technical data table

TYPE	Displacement cm3/rev	Max. Pressure		CODE	
		P1 bar	P3 bar	External drainage	Internal drainage
XV-3M/15	14,89	250	270	X 3 P 66 01 A D D E	X 3 P 66 02 A D D F
XV-3M/18	17,37	250	270	X 3 P 68 01 A D D E	X 3 P 68 02 A D D F
XV-3M/21	21,10	250	270	X 3 P 70 01 A D D E	X 3 P 70 02 A D D F
XV-3M/27	26,97	250	270	X 3 P 72 01 A E E E	X 3 P 72 02 A E E F
XV-3M/32	32,27	250	270	X 3 P 74 01 A E E E	X 3 P 74 02 A E E F
XV-3M/38	38,47	250	270	X 3 P 78 01 A E E E	X 3 P 78 02 A E E F
XV-3M/43	43,44	250	270	X 3 P 79 01 A E E E	X 3 P 79 02 A E E F
XV-3M/47	47,16	230	250	X 3 P 80 01 A E E E	X 3 P 80 02 A E E F
XV-3M/51	50,88	230	250	X 3 P 81 01 A E E E	X 3 P 81 02 A E E F
XV-3M/54	54,60	230	250	X 3 P 82 01 A E E E	X 3 P 82 02 A E E F
XV-3M/61	60,81	230	250	X 3 P 83 01 A F F E	X 3 P 83 02 A F F F
XV-3M/64	64,53	210	230	X 3 P 85 01 A F F E	X 3 P 85 02 A F F F
XV-3M/70	70,74	200	220	X 3 P 86 01 A F F E	X 3 P 86 02 A F F F
XV-3M/74	74,46	180	200	X 3 P 87 01 A F F E	X 3 P 87 02 A F F F
XV-3M/90	86,87	150	170	X 3 P 89 01 A F F E	X 3 P 89 02 A F F F

P1) Max. working pressure - P3) Max. peak pressure

For heavy-duty applications, it is recommended to check the admissible torque of the shaft

Dimensions table

TYPE	Weight	A	B	D	D
	kg	mm	mm	IN	OUT
XV-3M/15	7,010	122,0	61,0	3/4" BSPP	3/4" BSPP
XV-3M/18	7,070	124,0	62,0	3/4" BSPP	3/4" BSPP
XV-3M/21	7,150	127,0	63,5	3/4" BSPP	3/4" BSPP
XV-3M/27	7,250	131,0	65,5	1" BSPP	1" BSPP
XV-3M/32	7,390	136,0	68,0	1" BSPP	1" BSPP
XV-3M/38	7,520	141,0	70,5	1" BSPP	1" BSPP
XV-3M/43	7,630	145,0	72,5	1" BSPP	1" BSPP
XV-3M/47	7,710	148,0	74,0	1" BSPP	1" BSPP
XV-3M/51	7,790	151,0	75,5	1" BSPP	1" BSPP
XV-3M/54	7,870	154,0	77,0	1" BSPP	1" BSPP
XV-3M/61	8,010	159,0	79,5	1" 1/4 BSPP	1" 1/4 BSPP
XV-3M/64	8,090	162,0	81,0	1" 1/4 BSPP	1" 1/4 BSPP
XV-3M/70	8,220	167,0	83,5	1" 1/4 BSPP	1" 1/4 BSPP
XV-3M/74	8,300	170,0	85,0	1" 1/4 BSPP	1" 1/4 BSPP
XV-3M/90	8,570	180,0	90,0	1" 1/4 BSPP	1" 1/4 BSPP

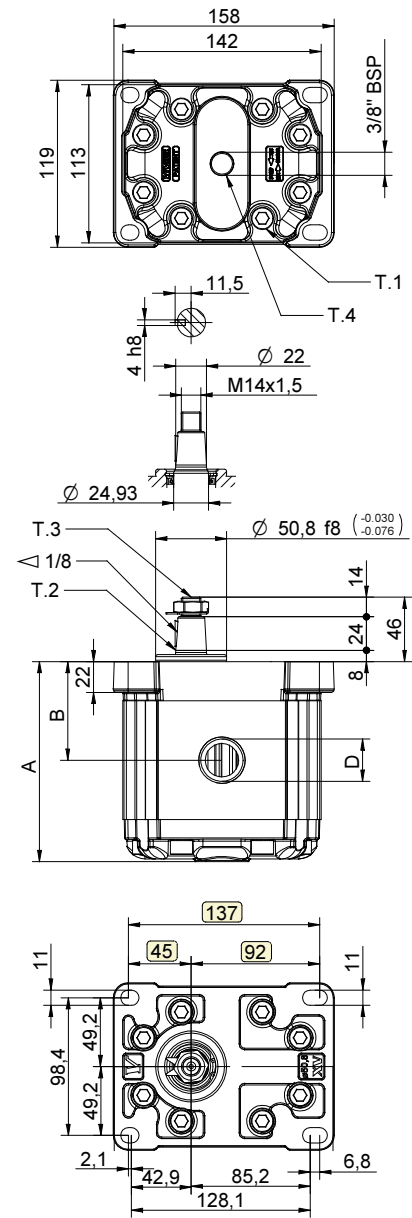

T.1 = 60÷65 [Nm] - screw tightening torque M10

T.3 = 75 [Nm] - torque wrench setting 22

T.2 = 482 [Nm] - admissible shaft torque (N.B. When choosing a shaft, always check the admissible torque).

T.4 = 0.3÷0.5 bar - max. drainage pressure

Table of variations

XV-3M

ø50.8 FLANGE

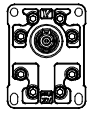
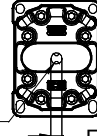
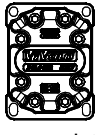
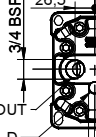
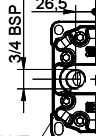
ø50.8 FLANGE		Shaft		Cover			
	01	CO001 - Tapered T.2 = 482 [Nm]	A	CI001 - Parallel T.2 = 181 [Nm]	B	 External drainage	E
		SCF03 - Splined T.2 = 223 [Nm]	C	CI004 - Parallel T.2 = 180 [Nm]	H	 Internal drainage	F
		SCF04 - Splined T.2 = 264 [Nm]	I			 IN + OUT + external	K
						 IN + OUT + internal	L

Displacement	
TYPE	CODE
XV-3M/15	66
XV-3M/18	68
XV-3M/21	70
XV-3M/27	72
XV-3M/32	74
XV-3M/38	78
XV-3M/43	79
XV-3M/47	80
XV-3M/51	81
XV-3M/54	82
XV-3M/61	83
XV-3M/64	85
XV-3M/70	86
XV-3M/74	87
XV-3M/90	89

Standard bodies				
Displacement cm ³ /rev	Standard threads			
	15	A - A	D - D	H - H
18	A - A	D - D	H - H	
21	A - A	D - D	H - H	
27	A - A	E - E	H - H	
32	B - B	E - E	H - H	
38	B - B	E - E	H - H	
43	B - B	E - E	H - H	
47	B - B	E - E	H - H	
51	B - B	E - E	H - H	
54	B - B	E - E	H - H	
61	C - C	F - F		
64	C - C	F - F		
70	C - C	F - F		
74	C - C	F - F		
90	C - C	F - F		

Table showing standard flange and thread combinations available in stock

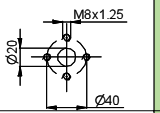
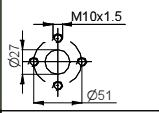
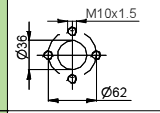
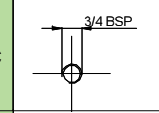
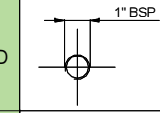
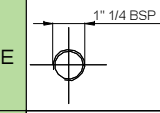
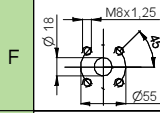
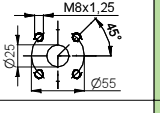
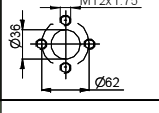
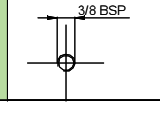
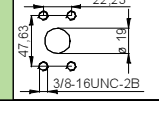
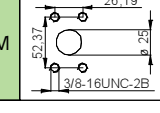
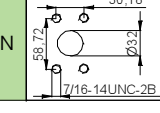
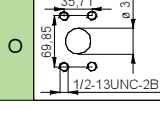
Body (threads/flanges)													
	A		B		C		D		E		F		G
	H		I		L		M		N		O		P
Closed Body	Z												

reversible motor - series XV

XV-3M

SAE B TYPE MOTOR
 ø101.6 FLANGE - SPLINED SHAFT



XM331

X 3 M 78 31 I E E E

Series	X	series XV
Group	3	group 3
Category	M	reversible motor
Displacement	78	38
Flange	31	Ø101.6 SAE B reversible rotation
Shaft	I	SCF04 - Splined ø21.81 z=13, H=33.55 SAE J498-13T -16/32DP (SAE B)
Body	IN	inlet - 1" BSP
	OUT	outlet - 1" BSP
Cover	E	with external drainage

Technical data table						
TYPE	Displacement cm3/rev	Max. Pressure		CODE		
		P1 bar	P3 bar	External drainage		Internal drainage
XV-3M/15	14,89	250	270	X 3 M 66 31 I D D E	X 3 M 66 31 I D D F	
XV-3M/18	17,37	250	270	X 3 M 68 31 I D D E	X 3 M 68 31 I D D F	
XV-3M/21	21,10	250	270	X 3 M 70 31 I D D E	X 3 M 70 31 I D D F	
XV-3M/27	26,97	250	270	X 3 M 72 31 I E E E	X 3 M 72 31 I E E F	
XV-3M/32	32,27	250	270	X 3 M 74 31 I E E E	X 3 M 74 31 I E E F	
XV-3M/38	38,47	250	270	X 3 M 78 31 I E E E	X 3 M 78 31 I E E F	
XV-3M/43	43,44	250	270	X 3 M 79 31 I E E E	X 3 M 79 31 I E E F	
XV-3M/47	47,16	230	250	X 3 M 80 31 I E E E	X 3 M 80 31 I E E F	
XV-3M/51	50,88	230	250	X 3 M 81 31 I E E E	X 3 M 81 31 I E E F	
XV-3M/54	54,60	230	250	X 3 M 82 31 I E E E	X 3 M 82 31 I E E F	
XV-3M/61	60,81	230	250	X 3 M 83 31 I F F E	X 3 M 83 31 I F F F	
XV-3M/64	64,53	210	230	X 3 M 85 31 I F F E	X 3 M 85 31 I F F F	
XV-3M/70	70,74	200	220	X 3 M 86 31 I F F E	X 3 M 86 31 I F F F	
XV-3M/74	74,46	180	200	X 3 M 87 31 I F F E	X 3 M 87 31 I F F F	
XV-3M/90	86,87	150	170	X 3 M 89 31 I F F E	X 3 M 89 31 I F F F	

P1) Max. working pressure - P3) Max. peak pressure

For heavy-duty applications, it is recommended to check the admissible torque of the shaft

Dimensions table					
TYPE	Weight	A	B	D	D
	kg	mm	mm	IN	OUT
XV-3M/15	7,010	124,0	61,0	3/4" BSPP	3/4" BSPP
XV-3M/18	7,070	126,0	62,0	3/4" BSPP	3/4" BSPP
XV-3M/21	7,150	129,0	63,5	3/4" BSPP	3/4" BSPP
XV-3M/27	7,250	133,0	65,5	1" BSPP	1" BSPP
XV-3M/32	7,390	138,0	68,0	1" BSPP	1" BSPP
XV-3M/38	7,520	143,0	70,5	1" BSPP	1" BSPP
XV-3M/43	7,630	147,0	72,5	1" BSPP	1" BSPP
XV-3M/47	7,710	150,0	74,0	1" BSPP	1" BSPP
XV-3M/51	7,790	153,0	75,5	1" BSPP	1" BSPP
XV-3M/54	7,870	156,0	77,0	1" BSPP	1" BSPP
XV-3M/61	8,010	161,0	79,5	1" 1/4 BSPP	1" 1/4 BSPP
XV-3M/64	8,090	164,0	81,0	1" 1/4 BSPP	1" 1/4 BSPP
XV-3M/70	8,220	169,0	83,5	1" 1/4 BSPP	1" 1/4 BSPP
XV-3M/74	8,300	172,0	85,0	1" 1/4 BSPP	1" 1/4 BSPP
XV-3M/90	8,570	182,0	90,0	1" 1/4 BSPP	1" 1/4 BSPP

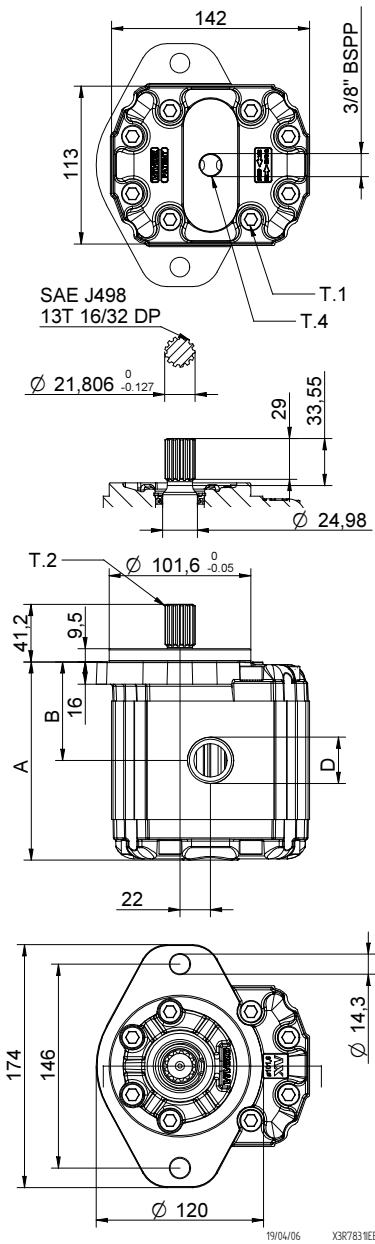

T.1 = 60÷65 [Nm] - screw tightening torque M10

T.2 = 264 [Nm] - admissible shaft torque (N.B. When choosing a shaft, always check the admissible torque).

T.4 = 0.3÷0.5 bar - max. drainage pressure

Table of variations

XV-3M

ø101.6 FLANGE ""SAE B""

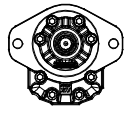
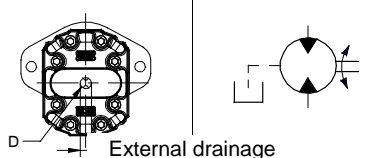
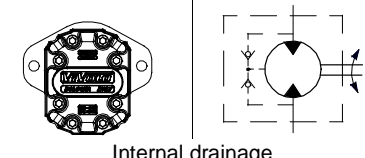
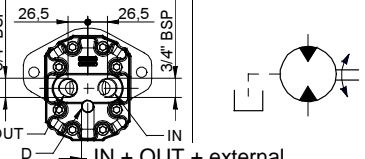
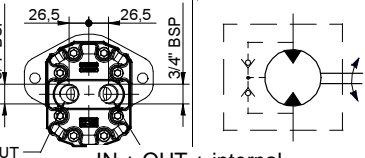
	Shaft		Cover			
	CO001 - Tapered T.2 = 482 [Nm]	A	CI001 - Parallel T.2 = 181 [Nm]	B	 External drainage	E
	SCF03 - Splined T.2 = 223 [Nm]	C	CI004 - Parallel T.2 = 180 [Nm]	H	 Internal drainage	F
	SCF04 - Splined T.2 = 264 [Nm]	I			 IN + OUT + external	K
				 IN + OUT + internal	L	

Displacement	
TYPE	CODE
XV-3M/15	66
XV-3M/18	68
XV-3M/21	70
XV-3M/27	72
XV-3M/32	74
XV-3M/38	78
XV-3M/43	79
XV-3M/47	80
XV-3M/51	81
XV-3M/54	82
XV-3M/61	83
XV-3M/64	85
XV-3M/70	86
XV-3M/74	87
XV-3M/90	89

Standard bodies				
Displacement cm ³ /rev	Standard threads			
	15	A - A	D - D	H - H
18	A - A	D - D	H - H	
21	A - A	D - D	H - H	
27	A - A	E - E	H - H	
32	B - B	E - E	H - H	
38	B - B	E - E	H - H	
43	B - B	E - E	H - H	
47	B - B	E - E	H - H	
51	B - B	E - E	H - H	
54	B - B	E - E	H - H	
61	C - C	F - F		
64	C - C	F - F		
70	C - C	F - F		
74	C - C	F - F		
90	C - C	F - F		

Table showing standard flange and thread combinations available in stock

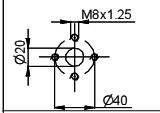
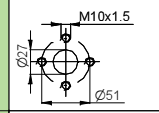
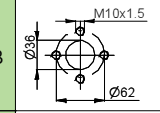
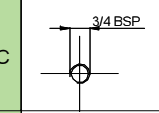
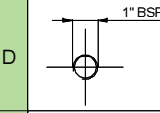
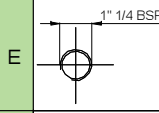
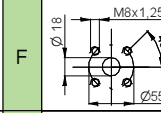
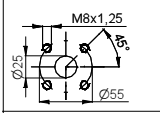
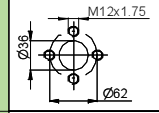
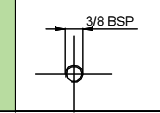
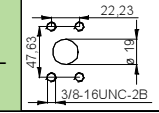
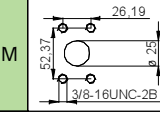
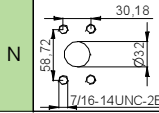
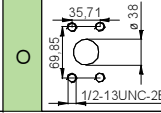
Body (threads/flanges)													
	A		B		C		D		E		F		G
	H		I		L		M		N		O		P
Closed Body	Z												

reversible motor - series XV

XV-3M

SAE B TYPE MOTOR
 ø101.6 FLANGE - SPLINED SHAFT

X 3 M 78 31 I O O E

Series	X	series XV
Group	3	group 3
Category	M	reversible motor
Displacement	78	38
Flange	31	Ø101.6 SAE B reversible rotation
Shaft	I	SCF04 - Splined ø21.81 z=13, H=33.55 SAE J498-13T -16/32DP (SAE B)
Body	IN	inlet - SAE 30,18 X 58,72 - ø32 - 7/16-14UNC-2B
	OUT	outlet - SAE 30,18 X 58,72 - ø32 - 7/16-14UNC-2B
Cover	E	with external drainage

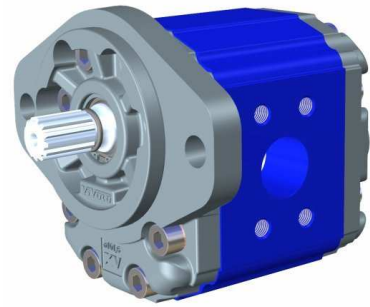

XM332

Technical data table

TYPE	Displacement cm3/rev	Max. Pressure		CODE	
		P1 bar	P3 bar	External drainage	Internal drainage
XV-3M/15	14,89	250	270	X 3 M 66 31 I N N E	X 3 M 66 31 I N N F
XV-3M/18	17,37	250	270	X 3 M 68 31 I N N E	X 3 M 68 31 I N N F
XV-3M/21	21,10	250	270	X 3 M 70 31 I N N E	X 3 M 70 31 I N N F
XV-3M/27	26,97	250	270	X 3 M 72 31 I N N E	X 3 M 72 31 I N N F
XV-3M/32	32,27	250	270	X 3 M 74 31 I O O E	X 3 M 74 31 I O O F
XV-3M/38	38,47	250	270	X 3 M 78 31 I O O E	X 3 M 78 31 I O O F
XV-3M/43	43,44	250	270	X 3 M 79 31 I O O E	X 3 M 79 31 I O O F
XV-3M/47	47,16	230	250	X 3 M 80 31 I O O E	X 3 M 80 31 I O O F
XV-3M/51	50,88	230	250	X 3 M 81 31 I O O E	X 3 M 81 31 I O O F
XV-3M/54	54,60	230	250	X 3 M 82 31 I O O E	X 3 M 82 31 I O O F
XV-3M/61	60,81	230	250	X 3 M 83 31 I P P E	X 3 M 83 31 I P P F
XV-3M/64	64,53	210	230	X 3 M 85 31 I P P E	X 3 M 85 31 I P P F
XV-3M/70	70,74	200	220	X 3 M 86 31 I P P E	X 3 M 86 31 I P P F
XV-3M/74	74,46	180	200	X 3 M 87 31 I P P E	X 3 M 87 31 I P P F
XV-3M/90	86,87	150	170	X 3 M 89 31 I P P E	X 3 M 89 31 I P P F

P1) Max. working pressure - P3) Max. peak pressure

For heavy-duty applications, it is recommended to check the admissible torque of the shaft

Dimensions table

TYPE	Weight kg	A	B	D	E	F	G
		mm	mm	IN - OUT			
XV-3M/15	7,010	124,0	61,0	ø25	52,37	26,19	3/8-16UNC-2B
XV-3M/18	7,070	126,0	62,0	ø25	52,37	26,19	3/8-16UNC-2B
XV-3M/21	7,150	129,0	63,5	ø25	52,37	26,19	3/8-16UNC-2B
XV-3M/27	7,250	133,0	65,5	ø25	52,37	26,19	3/8-16UNC-2B
XV-3M/32	7,390	138,0	68,0	ø32	58,72	30,18	7/16-14UNC-2B
XV-3M/38	7,520	143,0	70,5	ø32	58,72	30,18	7/16-14UNC-2B
XV-3M/43	7,630	147,0	72,5	ø32	58,72	30,18	7/16-14UNC-2B
XV-3M/47	7,710	150,0	74,0	ø32	58,72	30,18	7/16-14UNC-2B
XV-3M/51	7,790	153,0	75,5	ø32	58,72	30,18	7/16-14UNC-2B
XV-3M/54	7,870	156,0	77,0	ø32	58,72	30,18	7/16-14UNC-2B
XV-3M/61	8,010	161,0	79,5	ø38	69,85	35,71	1/2-13UNC-2B
XV-3M/64	8,090	164,0	81,0	ø38	69,85	35,71	1/2-13UNC-2B
XV-3M/70	8,220	169,0	83,5	ø38	69,85	35,71	1/2-13UNC-2B
XV-3M/74	8,300	172,0	85,0	ø38	69,85	35,71	1/2-13UNC-2B
XV-3M/90	8,570	182,0	90,0	ø38	69,85	35,71	1/2-13UNC-2B

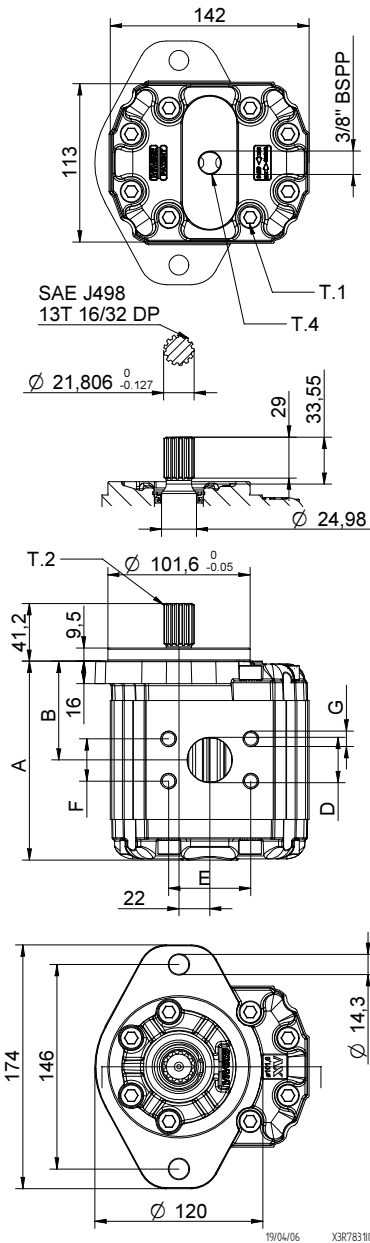

T.1 = 60÷65 [Nm] - screw tightening torque M10

T.2 = 264 [Nm] - admissible shaft torque (N.B. When choosing a shaft, always check the admissible torque).

T.4 = 0.3÷0.5 bar - max. drainage pressure

Table of variations

XV-3M

ø101.6 FLANGE ""SAE B""

	Shaft		Cover			
	CO001 - Tapered T.2 = 482 [Nm]	A	CI001 - Parallel T.2 = 181 [Nm]	B	External drainage	E
	SCF03 - Splined T.2 = 223 [Nm]	C	CI004 - Parallel T.2 = 180 [Nm]	H	Internal drainage	F
	SCF04 - Splined T.2 = 264 [Nm]	I			IN + OUT + external	K
				IN + OUT + internal	L	

Displacement	
TYPE	CODE
XV-3M/15	66
XV-3M/18	68
XV-3M/21	70
XV-3M/27	72
XV-3M/32	74
XV-3M/38	78
XV-3M/43	79
XV-3M/47	80
XV-3M/51	81
XV-3M/54	82
XV-3M/61	83
XV-3M/64	85
XV-3M/70	86
XV-3M/74	87
XV-3M/90	89

Standard bodies				
Displacement cm3/rev	Standard threads			
	15	A - A	D - D	H - H
18	A - A	D - D	H - H	
21	A - A	D - D	H - H	
27	A - A	E - E	H - H	
32	B - B	E - E	H - H	
38	B - B	E - E	H - H	
43	B - B	E - E	H - H	
47	B - B	E - E	H - H	
51	B - B	E - E	H - H	
54	B - B	E - E	H - H	
61	C - C	F - F		
64	C - C	F - F		
70	C - C	F - F		
74	C - C	F - F		
90	C - C	F - F		

Table showing standard flange and thread combinations available in stock

Body (threads/flanges)													
	A		B		C		D		E		F		G
	H		I		L		M		N		O		P
Closed Body	Z												

DOUBLE SHAFT - Variant VA

All versions may be supplied with a double shaft using all types of shafts and flanges
As per catalogue

Example of order code

Standard -----X0P0602ABBA
With double shaft -----X0P0602ABBA **VA**

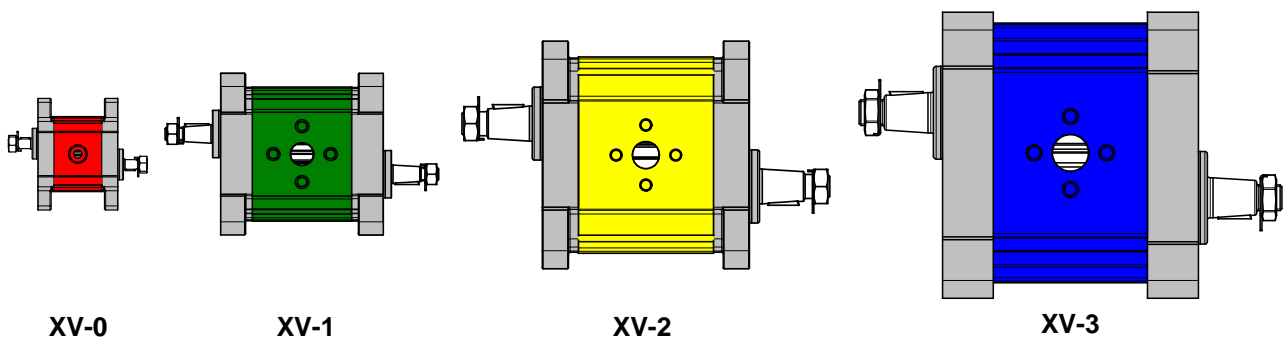

SEALS made of FKM (viton) variant VITON

All versions may be supplied with **FKM (viton)** seals

Example of order code

Standard-----X0P0602ABBA
With FKM (viton) seals -----X0P0602ABBA **VITON**

O-RINGS

Variant VDC		Oil seal with backup washer (standard for motors)
Variant VDCX		Double oil seal with double backup washer
Variant VDB		DUPLEX oil seal
Variant VDBX		Double opposed oil seal with backup washer
Variant VDCO		Motor Oil Seal with backup washer + Standard Oil Seal

Example of order code

Standard-----X1P0602FIIA
With oil seal and retaining washer -----X1P0602FIIA **VDC**

Pressure-relief valve VM25 for XV0 series

	Technical specifications	
	Capacity	25 l/min
	Max pressure in P	315 bars
	Max pressure in T	315 bars
	Setting range of spring Type 01	20-140 bars
	Setting range of spring Type 02	70-315 bars
	Required filtration	10-15 μ m
	Oil viscosity range	2.8-350 cSt
	Recommended oil temperature	-20 + 80 $^{\circ}$ C
	Seal material	Buna N
	Weight	0.110 kg
	Pressures with flow of 1 l/min: opening value in relation to setting	95%
	Closing value in relation to setting	75%
	Hydraulic oil	HM, HV ISO 6074

Pressure-relief valve VM50 for XV1 and XV2 series

	Technical specifications	
	Capacity	50/min
	Max pressure in P	350 bars
	Max pressure in T	350 bars
	Setting range of spring Type 01	10-105 bars
	Setting range of spring Type 02	70-210 bars
	Setting range of spring Type 03	140-350 bars
	Required filtration	10-15 μ m
	Oil viscosity range	2.8-350 cSt
	Recommended oil temperature	-20 + 80 $^{\circ}$ C
	Seal material	Buna N
	Weight	0.125 kg
	Pressures with flow of 1 l/min: opening value in relation to setting	95%
	Closing value in relation to setting	75%
	Hydraulic oil	HM, HV ISO 6074

Standard test settings

TYPE	Pressure (bars)	Capacity (l/min)	Pressure increase (bars x turn of screw)
1 (10-105 bars)	50	5	15
2 (70-210 bars)	130	5	32
3 (140-350 bars)	200	5	67

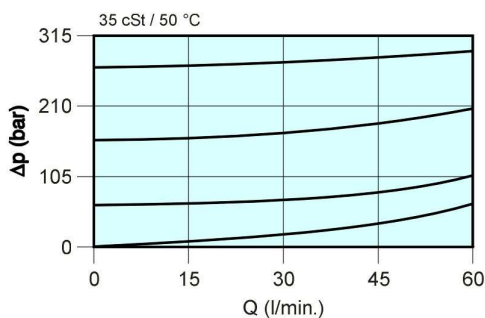

Performance of VM25 and VM50 valves

Δp = Pressure drop in bars

Q = Capacity in litres per minute

90° STEEL ELBOWS

Code	Type	A	B	C	D	E	F	G	OR	V	weigth
									O ring	Screw	
8KRG001	RG 26/12-3/8"BSP	3/8"	26	5,5	12	18	9,5	27	ø14,00x1,78	M5x18	0,13
8KRG002	RG 26/12-1/2"BSP	1/2"	26	5,5	12	18	9,5	27	ø14,00x1,78	M5x18	0,12
8KRG003	RG 30/13,5 -3/8"BSP	3/8"	30	6,5	13,5	18	9,5	27	ø15,88x2,62	M6x20	0,17
8KRG004	RG 30/13,5 -1/2"BSP	1/2"	30	6,5	13,5	18	9,5	27	ø15,88x2,62	M6x20	0,16
8KRG005	RG 40/20-1/2"BSP	1/2"	40	8,5	20	21	10,5	38	ø23,81x2,62	M8x25	0,36
8KRG006	RG 40/20-3/4"BSP	3/4"	40	8,5	20	21	10,5	38	ø23,81x2,62	M8x25	0,32
8KRG007	RG 40/23-3/4"BSP	3/4"	40	8,5	23,5	21	10,5	38	ø25,12x1,78	M8x25	0,29
8KRG008	RG 51/27-1"BSP	1"	51	10,5	27	27	13,5	47	ø31,42x2,62	M10x30	0,7
8KRG009	RG 51/27-3/4" BSP	3/4"	51	10,5	27	27	13,5	47	ø31,42x2,62	M10x30	0,7
8KRG011	RG 56/34-3/4" BSP	3/4"	56	10,5	34	27	13,5	47	ø37,77x2,62	M10x30	0,72
8KRG012	RG 62/36-1"1/4 BSP	1"1/4	62	10,5	36	36	19	56	ø41,28x3,53	M10x30	0,94
8KRG015	RG 62/36-1"1/4 BSP M12	1"1/4	62	12,5	36	36	19	56	ø41,28x3,53	M12x35	0,94
8KRG013	RG 72,5/45-1"1/2 BSP	1"1/2	72,5	12,5	45	38	16	58	ø49,20x3,53	M12x35	1,23
8KRG014	RG 92/65-2" BSP	2	92	12,5	65	50	21	75	ø69,85x3,53	M12x40	1,65

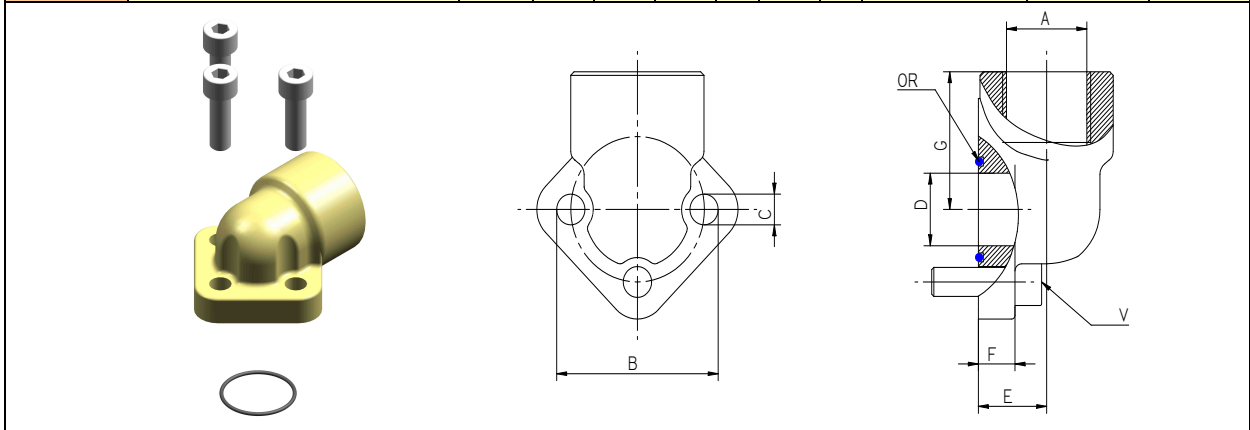

STRAIGHT STEEL UNIONS

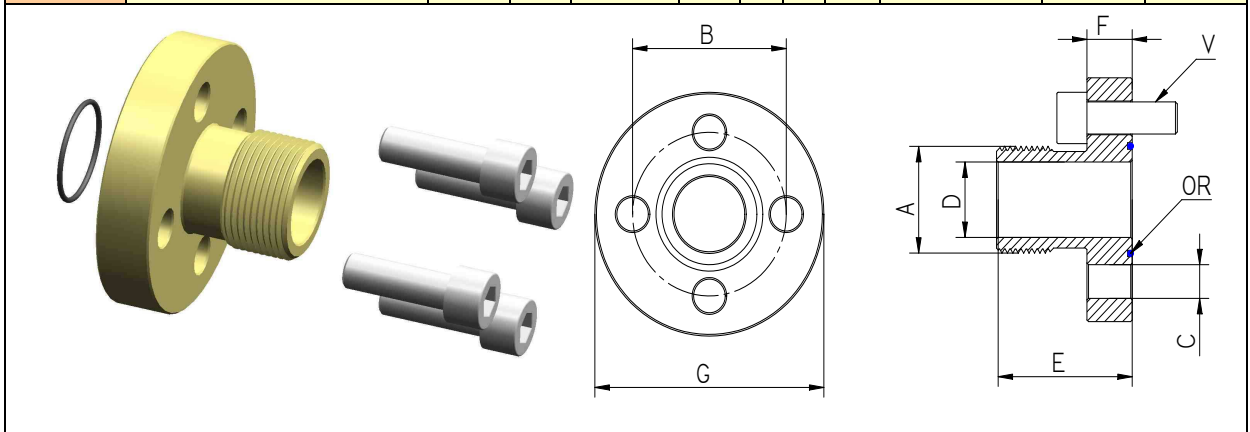
Code	Type	A	B	C	D	E	F	G	OR	V	Weigth
									O ring	Screw	
8KRD001	RD 26/12-3/8"BSP	3/8"	26	5,5	12	32	10	39	ø14,00x1,78	M5x18	0,11
8KRD002	RD 30/13,5-1/2"BSP	1/2"	30	6,5	13,5	40	10	44	ø15,88x2,62	M6x20	0,14
8KRD005	RD 40/20-3/4"BSP	3/4"	40	8,5	20	42	12	51	ø23,81x2,62	M8x25	0,3
8KRD006	RD 40/23,5-3/4"BSP	3/4"	40	8,5	23,5	42	12	51	ø25,12x1,78	M8x25	0,29
8KRD007	RD 51/27-1"BSP	1"	51	10,5	27	43	12	68	ø31,42x2,62	M10x25	0,46
8KRD008	RD 56/34-1"1/4 BSP	1" 1/4	56	10,5	34	53	12	73	ø37,77x2,62	M10x25	0,68
8KRD009	RD 62/36-1"1/4 BSP	1" 1/4	62	10,5	36	47	13	78	ø41,28x3,53	M10x25	0,9
8KRD010	RD 72,5/45-1"1/2 BSP	1" 1/2	72,5	12,5	45	49	14	89	ø49,20x3,53	M12x30	1,05
8KRD011	RD 92/65-2"1/2 BSP	2" 1/2	92	12,5	65	60	18	114	ø69,85x3,53	M12x40	1,15

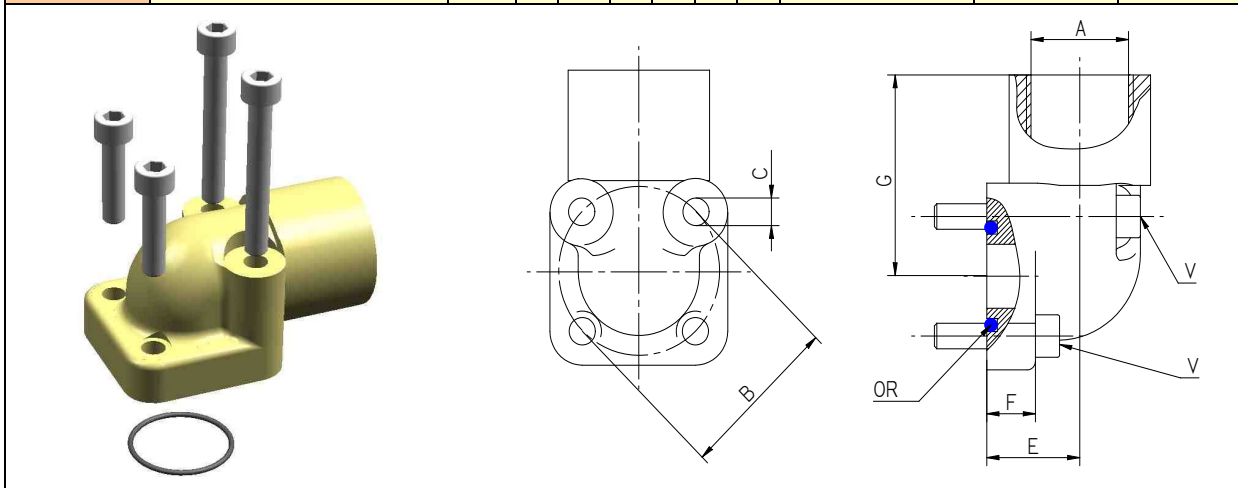

SQUARED STEEL ELBOWS

Code	Type	A	B	C	D	E	F	G	OR	V	Weight
									O ring	Screw	
8KRQ001	RQ 30/12-3/8"BSP	3/8"	30	6,5	12	19	11	41	ø15,88x2,61	Nº2 M6x20 Nº2 M6x35	0,29
8KRQ002	RQ 30/12-1/2"BSP	1/2"	30	6,5	12	19	11	41	ø15,88x2,62	Nº2 M6x20 Nº2 M6x35	0,29
8KRQ003	RQ 35/15 -3/8"BSP	3/8"	35	6,5	15	18	11	40	ø18,72x2,62	Nº2 M6x20 Nº2 M6x35	0,34
8KRQ004	RQ 35/15 -1/2"BSP	1/2"	35	6,5	15	18	11	40	ø18,72x2,62	Nº2 M6x20 Nº2 M6x35	0,34
8KRQ005	RQ 40/20-1/2"BSP	1/2"	40	6,5	20	24	10	45	ø22,22x2,62	Nº2 M6x25 Nº2 M6x45	0,4
8KRQ006	RQ 40/20-3/4"BSP	3/4"	40	6,5	20	24	10	45	ø22,22x2,62	Nº2 M6x25 Nº2 M6x45	0,4
8KRQ007	RQ 55/25-3/4"BSP	3/4"	55	8,5	25	35	13	54	ø29,75x3,53	Nº2 M8x25 Nº2 M8x60	0,45
8KRQ008	RQ 55/25-1" BSP	1"	55	8,5	25	35	13	54	ø29,75x3,53	Nº2 M8x25 Nº2 M8x60	0,45

STRAIGHT STEEL UNIONS

Code	Type	A	B	C	D	E	F	G	OR	V	Weight
									O ring	Screw	
8KRD003	RD 35/15 (BH)-1/2"BSP	1/2"	35	6,5	14	35	10	40	ø18,72x2,62	M6x20	0,15
8KRD004	RD 40/20 (BH)-3/4"BSP	3/4"	40	6,5	17	35	10	40	ø22,22x2,62	M6x20	0,17

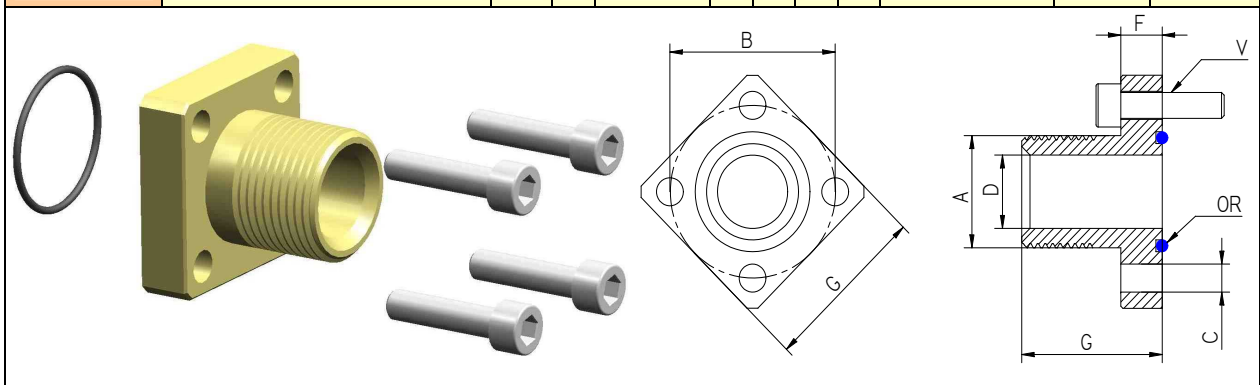

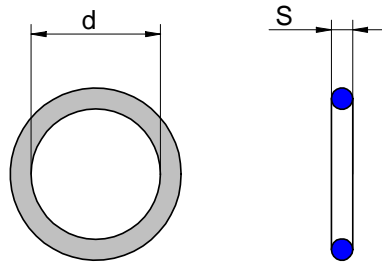
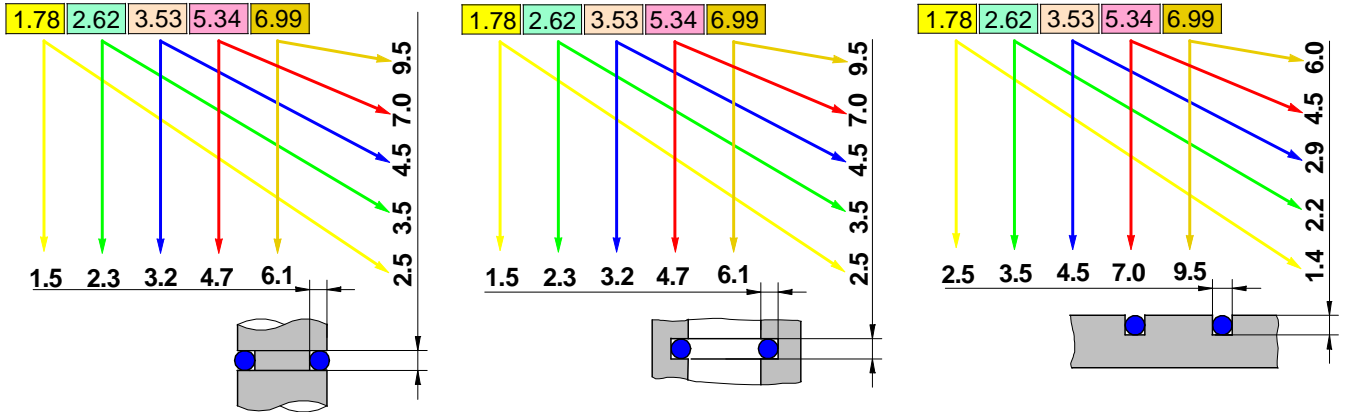

S=1,78		S=2,62				S=3,53				S=5,34				S=6,99		
1,78	33,05	9,13	34,60	82,22	247,33	18,64	52,39	88,50	190,1	37,43	107,2	158,12	481,46	113,7	181,0	342,3
2,57	34,65	9,19	36,14	88,57		20,22	53,37	91,67	196,4	40,65	109,5	164,47	506,86	114,7	183,5	354,9
2,90	37,82	9,92	37,77	94,92		21,82	53,98	94,84	202,8	43,82	110,5	170,82	532,26	116,8	187,3	367,7
3,68	41,00	10,78	39,34	101,27		23,40	55,56	98,02	209,1	47,00	113,7	117,17	557,66	120,0	189,9	380,3
4,47	44,17	11,91	40,95	107,63		24,99	56,74	101,2	215,5	50,16	116,84	183,52	582,68	123,2	193,7	393,1
5,28	47,35	12,37	42,52	113,98		25,80	57,15	104,4	221,8	53,34	117,5	189,87	608,08	124,6	196,2	
6,07	50,52	13,10	44,12	120,33		26,58	58,74	107,5	228,2	56,52	120,02	196,22	633,48	126,4	200,0	
6,75	53,70	13,95	45,69	126,67		28,17	59,92	110,7	234,5	59,69	120,7	202,57	658,88	129,5	202,6	
7,65	56,87	15,08	47,30	133,00		29,75	60,33	113,9	240,9	62,87	123,2	208,92		132,7	208,9	
8,73	60,05	15,54	48,99	139,38		31,34	61,91	117,1	247,2	66,04	123,8	215,27		134,5	215,3	
9,25	63,22	15,88	50,47	145,73		32,93	63,09	120,2	253,6	69,22	126,37	221,62		135,9	221,6	
10,82	66,40	17,13	52,07	152,07		34,52	63,50	123,4	266,3	72,39	127,0	227,97		139,1	227,9	
11,11	69,57	17,86	53,65	158,43		36,10	56,09	126,6	279,0	74,63	129,54	234,32		142,2	234,3	
12,42	72,75	18,72	55,25	164,78		37,89	66,27	129,8	291,7	75,57	130,2	240,67		145,4	240,7	
14,00	75,92	20,29	56,82	171,13		39,69	66,68	132,9	304,4	78,74	132,72	247,02		148,6	247,0	
15,60	82,27	20,63	58,42	177,48		40,89	68,26	136,1	329,8	79,77	133,4	253,37		151,8	253,3	
17,17	88,62	21,89	60,00	183,83		41,28	69,44	139,3	355,2	81,92	135,9	266,07		155,6	259,7	
18,77	94,97	22,22	61,60	190,18		42,86	69,85	142,5	380,6	85,09	136,5	278,77		158,1	266,1	
20,35	101,32	23,47	63,17	196,53		44,04	71,44	145,6	405,2	88,27	139,07	291,5		159,5	272,4	
31,95	107,67	23,81	64,77	202,88		44,45	72,62	148,8	430,6	89,69	139,7	304,17		161,9	278,7	
23,52	114,02	25,07	66,35	209,23		46,04	73,03	152,0	456,0	91,44	142,9	329,57		164,5	285,1	
25,12	120,37	26,65	67,95	215,58		47,22	74,61	158,3		94,62	145,42	354,97		166,7	291,5	
26,70	126,72	28,25	69,52	221,93		47,63	75,80	164,7		97,79	146,1	380,37		168,3	297,8	
28,30	133,07	29,82	71,12	228,28		49,21	78,97	171,0		100,0	148,6	405,26		170,8	304,1	
29,87		31,42	72,69	234,63		50,39	82,14	177,4		101,0	149,2	430,66		174,6	316,9	
31,47		32,99	75,87	240,98		50,80	85,32	183,7		104,1	151,77	456,06		177,2	329,6	

Speed m/sec	Capacities - l/min																				
	320	340	360	380	400	420	440	460	480	500	520	540	560	580	600	620	640	660	680	700	
Inlet	0,5	116,5	120,1	123,5	126,9	130,2	133,4	136,6	139,7	142,7	145,6	148,5	151,3	154,1	156,8	159,5	162,1	164,7	167,3	169,8	172,3
	1,0	82,4	84,9	87,4	89,8	92,1	94,4	96,6	98,8	100,9	103,0	105,0	107,0	109,0	110,9	112,8	114,6	116,5	118,3	120,1	121,8
	1,3	73,7	75,9	78,1	80,3	82,4	84,4	86,4	88,3	90,2	92,1	93,9	95,7	97,5	99,2	100,9	102,5	104,2	105,8	107,4	109,0
	1,5	67,3	69,3	71,3	73,3	75,2	77,0	78,9	80,6	82,4	84,1	85,7	87,4	89,0	90,5	92,1	93,6	95,1	96,6	98,0	99,5
Return	1,8	62,3	64,2	66,0	67,8	69,6	71,3	73,0	74,6	76,3	77,8	79,4	80,9	82,4	83,8	85,3	86,7	88,1	89,4	90,8	92,1
	2,0	58,2	60,0	61,8	63,5	65,1	66,7	68,3	69,8	71,3	72,8	74,2	75,7	77,0	78,4	79,7	81,1	82,4	83,6	84,9	86,1
	2,5	52,1	53,7	55,3	56,8	58,2	59,7	61,1	62,5	63,8	65,1	66,4	67,7	68,9	70,1	71,3	72,5	73,7	74,8	75,9	77,0
Outlet	3,0	47,6	49,0	50,4	51,8	53,2	54,5	55,8	57,0	58,2	59,4	60,6	61,8	62,9	64,0	65,1	66,2	67,3	68,3	69,3	70,3
	3,5	44,0	45,4	46,7	48,0	49,2	50,4	51,6	52,8	53,9	55,0	56,1	57,2	58,2	59,3	60,3	61,3	62,3	63,2	64,2	65,1
	4,0	41,2	42,4	43,7	44,9	46,0	47,2	48,3	49,4	50,4	51,5	52,5	53,5	54,5	55,4	56,4	57,3	58,2	59,1	60,0	60,9
	4,5	38,8	40,0	41,2	42,3	43,4	44,5	45,5	46,6	47,6	48,5	49,5	50,4	51,4	52,3	53,2	54,0	54,9	55,8	56,6	57,4
	5,0	36,8	38,0	39,1	40,1	41,2	42,2	43,2	44,2	45,1	46,0	47,0	47,8	48,7	49,6	50,4	51,3	52,1	52,9	53,7	54,5
	5,5	35,1	36,2	37,3	38,3	39,3	40,2	41,2	42,1	43,0	43,9	44,8	45,6	46,5	47,3	48,1	48,9	49,7	50,4	51,2	51,9
	6,0	33,6	34,7	35,7	36,6	37,6	38,5	39,4	40,3	41,2	42,0	42,9	43,7	44,5	45,3	46,0	46,8	47,6	48,3	49,0	49,7
	6,5	32,3	33,3	34,3	35,2	36,1	37,0	37,9	38,7	39,6	40,4	41,2	42,0	42,7	43,5	44,2	45,0	45,7	46,4	47,1	47,8
	7,0	31,1	32,1	33,0	33,9	34,8	35,7	36,5	37,3	38,1	38,9	39,7	40,4	41,2	41,9	42,6	43,3	44,0	44,7	45,4	46,0
	7,5	30,1	31,0	31,9	32,8	33,6	34,5	35,3	36,1	36,8	37,6	38,3	39,1	39,8	40,5	41,2	41,9	42,5	43,2	43,8	44,5
	8,0	29,1	30,0	30,9	31,7	32,6	33,4	34,1	34,9	35,7	36,4	37,1	37,8	38,5	39,2	39,9	40,5	41,2	41,8	42,4	43,1
	8,5	28,3	29,1	30,0	30,8	31,6	32,4	33,1	33,9	34,6	35,3	36,0	36,7	37,4	38,0	38,7	39,3	40,0	40,6	41,2	41,8
	9,0	27,5	28,3	29,1	29,9	30,7	31,5	32,2	32,9	33,6	34,3	35,0	35,7	36,3	37,0	37,6	38,2	38,8	39,4	40,0	40,6
	9,5	26,7	27,5	28,3	29,1	29,9	30,6	31,3	32,0	32,7	33,4	34,1	34,7	35,4	36,0	36,6	37,2	37,8	38,4	39,0	39,5
10,0	26,0	26,8	27,6	28,4	29,1	29,8	30,5	31,2	31,9	32,6	33,2	33,8	34,5	35,1	35,7	36,3	36,8	37,4	38,0	38,5	
Speed m/sec	Inner pipe diameter - mm																				

$d =$ Inner pipe diameter [mm]	$d = \sqrt{\frac{Q \cdot 21.2}{V}} [mm] \quad V = \frac{Q \cdot 21.2}{d^2} [m/sec] \quad Q = \frac{d^2 \cdot V}{21.2} [l/min]$
$Q =$ Capacities [l]	
$V =$ Speed [m/sec]	

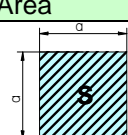
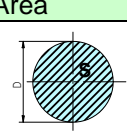
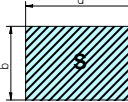
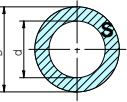
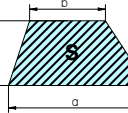
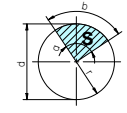
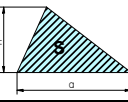
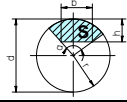
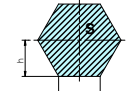
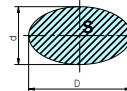
Table of Areas and Perimeters			
S= Area	S= Area	S= Area	
	$S = a^2$ $P = a \times 4$		$S = \pi/4 \times D^2$ $P = \pi \times D$
	$S = a \times b$ $P = 2(a + b)$		$S = \pi/4 \times (D^2 - d^2)$
	$S = (a + b) \times h/2$		$S = \pi \times r^2 \times \alpha / 360^\circ$ $b = \pi \times \alpha \times d / 360^\circ$
	$S = a \times h/2$		$S = (\pi r^2 \alpha / 360^\circ) - (b \times (r - h) / 2)$
	$S = 3 \times a \times h$		$S = \pi/4 \times D \times d$

Mpa	bar	Kg/cm ²	PSI	bar	Mpa	Kg/cm ²	PSI	Kg/cm ²	Mpa	bar	PSI	PSI	Mpa	bar	Kg/cm ²
1	10	10,19	145,14	1	0,1	1,019	14,5	1	0,902	0,981	14,22	1	0,007	0,069	0,0703
2	20	20,38	290,28	2	0,2	2,038	29	2	1,902	1,962	28,44	2	0,014	0,138	0,1406
3	30	30,57	435,42	3	0,3	3,057	43,5	3	2,902	2,943	42,66	3	0,021	0,207	0,2109
4	40	40,76	580,56	4	0,4	4,076	58	4	3,902	3,924	56,88	4	0,028	0,276	0,2812
5	50	50,95	725,7	5	0,5	5,095	72,5	5	4,902	4,905	71,1	5	0,035	0,345	0,3515
6	60	61,14	870,84	6	0,6	6,114	87	6	5,902	5,886	85,32	6	0,042	0,414	0,4218
7	70	71,33	1016	7	0,7	7,133	101,5	7	6,902	6,867	99,54	7	0,049	0,483	0,4921
8	80	81,52	1161,1	8	0,8	8,152	116	8	7,902	7,848	113,76	8	0,056	0,552	0,5624
9	90	91,71	1306,3	9	0,9	9,171	130,5	9	8,902	8,829	127,98	9	0,063	0,621	0,6327
10	100	101,9	1451,4	10	1	10,19	145	10	9,902	9,81	142,2	10	0,07	0,69	0,703
20	200	203,8	2902,8	20	2	20,38	290	20	19,902	19,62	284,4	20	0,14	1,38	1,406
30	300	305,7	4354,2	30	3	30,57	435	30	29,902	29,43	426,6	30	0,21	2,07	2,109
40	400	407,6	5805,6	40	4	40,76	580	40	39,902	39,24	568,8	40	0,28	2,76	2,812
50	500	509,5	7257	50	5	50,95	725	50	49,902	49,05	711	50	0,35	3,45	3,515
60	600	611,4	8708,4	60	6	61,14	870	60	59,902	58,86	853,2	60	0,42	4,14	4,218
70	700	713,3	10160	70	7	71,33	1015	70	69,902	68,67	995,4	70	0,49	4,83	4,921
80	800	815,2	11611	80	8	81,52	1160	80	79,902	78,48	1137,6	80	0,56	5,52	5,624
90	900	917,1	13063	90	9	91,71	1305	90	89,902	88,29	1279,8	90	0,63	6,21	6,327
100	1000	1019	14514	100	10	101,9	1450	100	99,902	98,1	1422	100	0,7	6,9	7,03
110	1100	1120,9	15965	110	11	112,09	1595	110	109,9	107,91	1564,2	110	0,77	7,59	7,733
120	1200	1222,8	17417	120	12	122,28	1740	120	119,9	117,72	1706,4	120	0,84	8,28	8,436
130	1300	1324,7	18868	130	13	132,47	1885	130	129,9	127,53	1848,6	130	0,91	8,97	9,139
140	1400	1426,6	20320	140	14	142,66	2030	140	139,9	137,34	1990,8	140	0,98	9,66	9,842
150	1500	1528,5	21771	150	15	152,85	2175	150	149,9	147,15	2133	150	1,05	10,35	10,545
160	1600	1630,4	23222	160	16	163,04	2320	160	159,9	156,96	2275,2	160	1,12	11,04	11,248
170	1700	1732,3	24674	170	17	173,23	2465	170	169,9	166,77	2417,4	170	1,19	11,73	11,951
180	1800	1834,2	26125	180	18	183,42	2610	180	179,9	176,58	2559,6	180	1,26	12,42	12,654
190	1900	1936,1	27577	190	19	193,61	2755	190	189,9	186,39	2701,8	190	1,33	13,11	13,357
200	2000	2038	29028	200	20	203,8	2900	200	199,9	196,2	2844	200	1,4	13,8	14,06
210	2100	2139,9	30479	210	21	213,99	3045	210	209,9	206,01	2986,2	210	1,47	14,49	14,763
220	2200	2241,8	31931	220	22	224,18	3190	220	219,9	215,82	3128,4	220	1,54	15,18	15,466
230	2300	2343,7	33382	230	23	234,37	3335	230	229,9	225,63	3270,6	230	1,61	15,87	16,169
240	2400	2445,6	34834	240	24	244,56	3480	240	239,9	235,44	3412,8	240	1,68	16,56	16,872
250	2500	2547,5	36285	250	25	254,75	3625	250	249,9	245,25	3555	250	1,75	17,25	17,575
260	2600	2649,4	37736	260	26	264,94	3770	260	259,9	255,06	3697,2	260	1,82	17,94	18,278
270	2700	2751,3	39188	270	27	275,13	3915	270	269,9	264,87	3839,4	270	1,89	18,63	18,981
280	2800	2853,2	40639	280	28	285,32	4060	280	279,9	274,68	3981,6	280	1,96	19,32	19,684
290	2900	2955,1	42091	290	29	295,51	4205	290	289,9	284,49	4123,8	290	2,03	20,01	20,387
300	3000	3057	43542	300	30	305,7	4350	300	299,9	294,3	4266	300	2,1	20,7	21,09
310	3100	3158,9	44993	310	31	315,89	4495	310	309,9	304,11	4408,2	310	2,17	21,39	21,793
320	3200	3260,8	46445	320	32	326,08	4640	320	319,9	313,92	4550,4	320	2,24	22,08	22,496
330	3300	3362,7	47896	330	33	336,27	4785	330	329,9	323,73	4692,6	330	2,31	22,77	23,199
340	3400	3464,6	49348	340	34	346,46	4930	340	339,9	333,54	4834,8	340	2,38	23,46	23,902
350	3500	3566,5	50799	350	35	356,65	5075	350	349,9	343,35	4977	350	2,45	24,15	24,605
Mpa= 0,1 bar Mpa= 0,098 Kg/cm ² Mpa= 0,007 PSI				bar= 10 MPa bar= 0,981 Kg/cm ² bar= 0,069 PSI				Kg/cm ² = 10,19 MPa Kg/cm ² = 1,019 bar Kg/cm ² = 0,0703 PSI				PSI= 145,14 MPa PSI= 14,5 bar PSI= 14,22 kg/cm ²			

Inches -> Millimetres 1Poll. = 25,40 mm							
in	mm	in	mm	in	mm	in	mm
1/64	0,397	1 1/2	38,1	15	381	36	914,4
1/32	0,764	1 3/4	44,45	16	406,4	38	965,2
3/64	1,191	2	50,8	17	431,8	40	1016
1/16	1,588	2 1/2	63,5	18	457,2	42	1066,8
3/32	2,381	3	76,2	19	482,6	44	1117,6
1/8	3,175	3 1/2	88,9	20	508	46	1168,4
5/32	3,969	4	101,6	21	533,4	48	1219,2
3/16	4,763	4 1/2	114,3	22	558,8	50	1270
1/4	6,35	5	127	23	584,2	55	1397
5/16	7,938	6	152,4	24	609,6	60	1524
3/8	9,525	7	177,8	25	635	65	1651
7/16	11,11	8	203,2	26	660,4	70	1778
1/2	12,7	9	228,6	27	685,8	75	1905
5/8	15,88	10	254	28	711,2	80	2032
3/4	19,05	11	279,4	29	736,6	85	2159
7/8	22,23	12	304,8	30	762	90	2286
1	25,4	13	330,2	32	812,8	95	2413
1 1/4	31,75	14	355,6	34	863,6	100	2540

Millimetres -> Inches 1 mm = 0,03937008 pollici							
mm	in	mm	in	mm	in	mm	in
1	0,039	28	1,102	130	5,12	750	29,53
2	0,079	30	1,181	140	5,51	800	31,50
3	0,118	35	1,378	150	5,91	850	33,46
4	0,157	40	1,575	160	6,30	900	35,43
5	0,197	45	1,772	170	6,69	950	37,40
6	0,236	50	1,969	180	7,09	1000	39,37
7	0,276	55	2,165	190	7,48	1250	49,21
8	0,315	60	2,362	200	7,87	1500	59,06
9	0,354	65	2,559	250	9,84	1750	68,90
10	0,394	70	2,756	300	11,81	2000	78,74
11	0,433	75	2,953	350	13,78	2500	98,43
12	0,472	80	3,150	400	15,75	3000	118,11
14	0,551	85	3,346	450	17,72	3500	137,80
16	0,630	90	3,543	500	19,69	4000	157,48
18	0,709	95	3,740	550	21,65	4500	177,17
20	0,787	100	3,937	600	23,62	5000	196,85
22	0,866	110	4,331	650	25,59	7500	295,28
26	1,024	120	4,724	700	27,56	10000	393,70

US Gallons -> Litres 1gallone = 3,785334 litri							
gal.	litri	gal.	litri	gal.	litri	gal.	litri
1	3,79	10	37,85	100	378,5	500	1893
2	7,57	20	75,71	120	454,2	600	2271
3	11,36	30	113,6	140	529,9	700	2650
4	15,14	40	151,4	160	605,7	800	3028
5	18,93	50	189,3	180	681,4	900	3407
6	22,71	60	227,1	200	757,1	1000	3785
7	26,50	70	265,0	250	946,3	1500	5678
8	30,28	80	302,8	300	1136	2000	7571
9	34,07	90	340,7	400	1514	3000	11356

Litres -> US Gallons 1litro = 0,2641775 galloni							
litri	gal.	litri	gal.	litri	gal.	litri	gal.
1	0,264	10	2,642	300	79,25	3000	792,5
2	0,528	20	5,284	400	105,7	4000	1057
3	0,793	30	7,925	500	132,1	5000	1321
4	1,057	40	10,57	600	158,5	6000	1585
5	1,321	50	13,21	700	184,9	8000	2113
6	1,585	100	26,42	800	211,3	10000	2642
7	1,849	150	39,63	900	237,8	20000	5284
8	2,113	200	52,84	1000	264,2	30000	7925
9	2,378	250	66,04	2000	528,4	50000	13209

Horsepower => Kilowatts 1 CV = 0,735 kW							
CV	Kw	CV	Kw	CV	Kw	CV	Kw
1	0,74	9	6,62	24	17,64	60	44,10
2	1,47	10	7,35	26	19,11	70	51,45
3	2,21	12	8,82	28	20,58	80	58,80
4	2,94	14	10,29	30	22,05	90	66,15
5	3,68	16	11,76	35	25,73	100	73,50
6	4,41	18	13,23	40	29,40	150	110,25
7	5,15	20	14,70	45	33,08	200	147,00
8	5,88	22	16,17	50	36,75	300	220,50

Kilowatts=>Horsepower 1 kW = 1,36 CV							
Kw	CV	Kw	CV	Kw	CV	Kw	CV
1	1,36	9	12,24	24	32,64	60	81,6
2	2,72	10	13,6	26	35,36	70	95,2
3	4,08	12	16,32	28	38,08	80	108,8
4	5,44	14	19,04	30	40,8	90	122,4
5	6,8	16	21,76	35	47,6	100	136
6	8,16	18	24,48	40	54,4	150	204
7	9,52	20	27,2	45	61,2	200	272
8	10,88	22	29,92	50	68	300	408

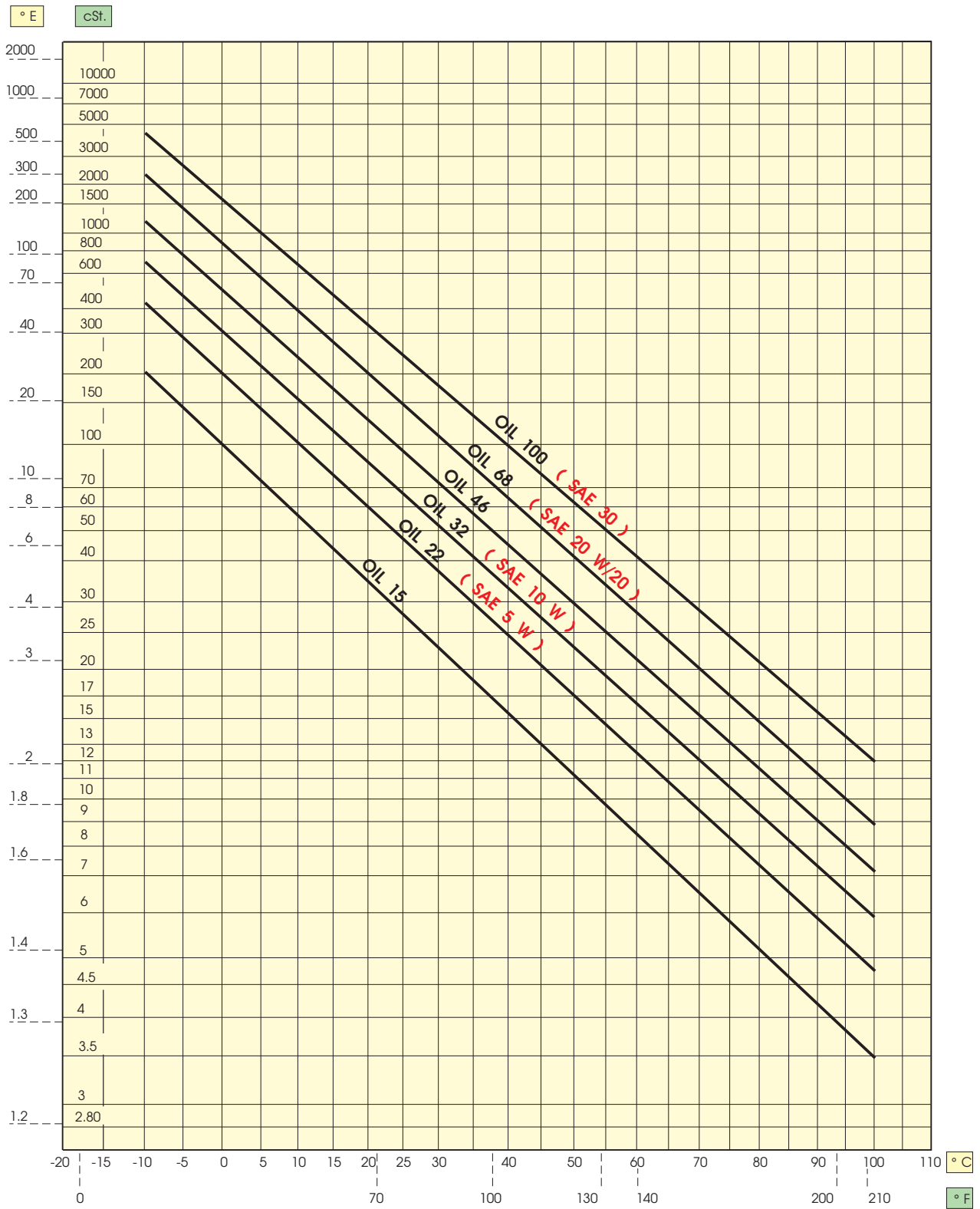



Table of pressure drops

Note: based on the oil viscosity and capacity of a pump it is possible to determine the pressure drop for every 100 m of piping by means of the table.

On the viscosity, flow rate and internal pipe diameter scales, fix the corresponding values **V**, **Q** and **D**.

Join points **V** and **Q** with a straight line intersecting point **I** on the "index" line.

From this point **I**, pass a straight line through **D** until meeting the pressure drop scale at point **P**; the corresponding value represents the pressure drop at point **P**; the corresponding value represents the pressure drop along 100 m of piping.

EXAMPLE: a pipe through which a fluid having a viscosity of 150 cSt. flows at a rate of 200 l/min and which has a diameter of 40 mm will have a pressure drop of 1 kg/cm² for every 100 m of length.

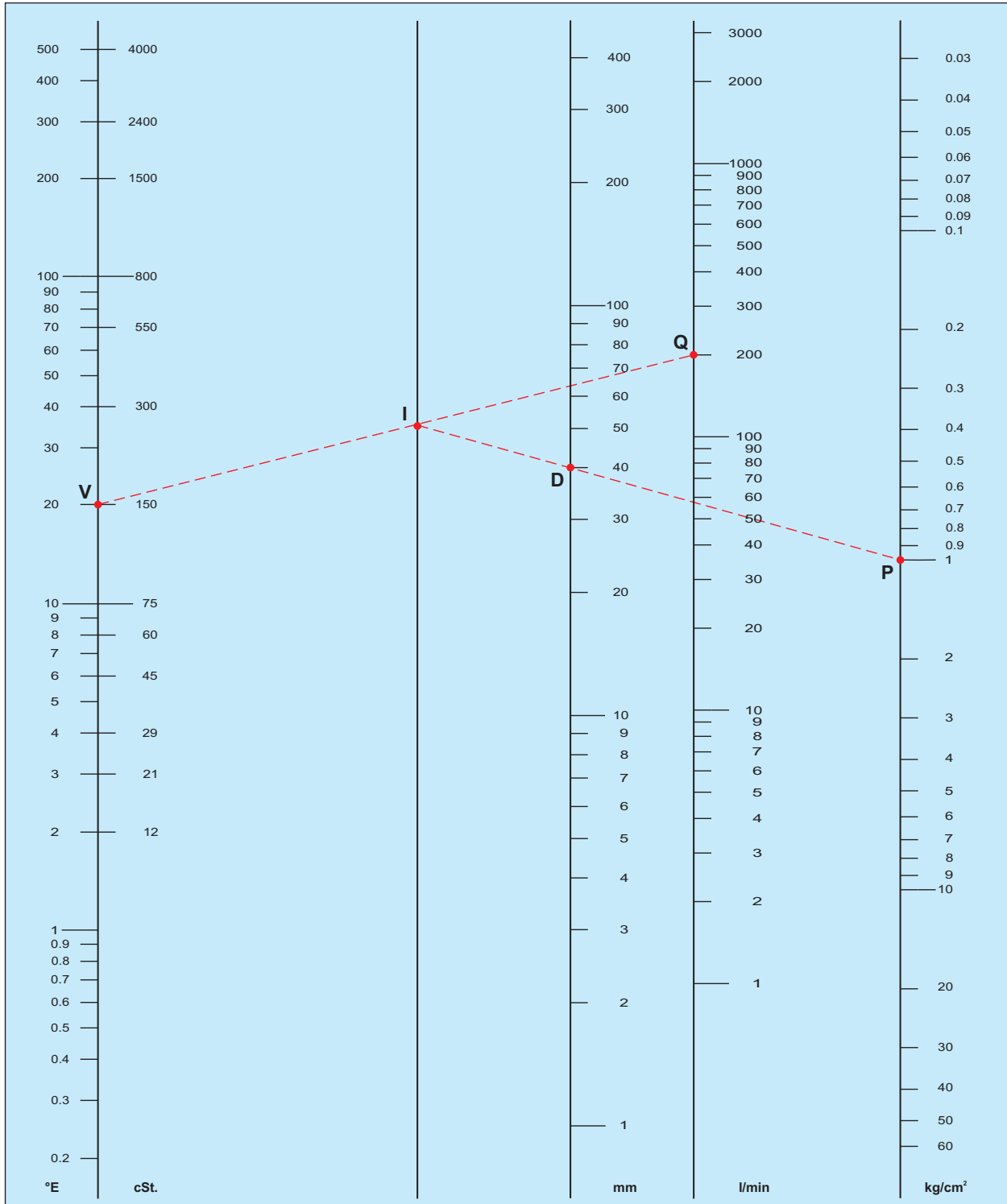

V= Viscosity cSt -°E

I= Index line of intersection

D= Internal pipe diameter in mm

Q= Flow rate in l/min

P= Pressure drop kg/cm² per 100 m

Table of elements

Element	Symbol	Atomic N°	Atom. Wgt.	Melt. point °C
Hafnium	Hf	72	178,49	2150,00
Aluminium	Al	13	26,98	660,37
Americium	Am	95	243,00	994,00
Antimony	Sb	51	121,75	630,00
Silver	Ag	47	107,87	961,93
Argon	Ar	18	39,95	-189,30
Arsenic	As	33	74,92	817,00
Astetina	At	85	210,00	302,00
Actinium	Ac	89	227,00	1050,00
Nitrogen	N	7	14,01	-209,90
Barium	Ba	56	137,33	725,00
Beryllium	Be	4	9,01	1278,00
Berkelium	Bk	97	247,00	
Bismuth	Bi	83	208,98	271,30
Boron	B	5	10,81	2300,00
Bromine	Br	35	79,90	-7,20
Cadmium	Cd	48	112,41	320,90
Calcium	Ca	20	40,08	839,00
Californium	Cf	98	251,00	
Carbon	C	6	12,01	3500,00
Cerium	Ce	58	140,12	795,00
Cesium	Cs	55	132,91	28,50
Chlorine	Cl	17	35,45	-100,98
Cobalt	Co	27	58,93	1495,00
Krypton	Kr	36	83,80	-157,20
Chromium	Cr	24	52,00	1857,00
Curium	Cm	96	247,00	1340,00
Dysprosium	Dy	66	162,50	1412,00
Einsteinium	Es	99	254,00	
Helium	He	2	4,00	-272,00
Erbium	Er	68	167,26	1522,00
Europium	Eu	63	151,96	822,00
Fermium	Fm	100	257,00	
Iron	Fe	26	55,85	1535,00

Element	Symbol	Atomic N°	Atom. Wgt.	Melt. point °C
Fluorine	F	9	19,00	-219,62
Phosphorus	P	15	30,97	44,10
Francium	Fr	87	223,00	27,00
Gadolinium	Gd	64	157,25	1311,00
Gallium	Ga	31	69,74	29,78
Germanium	Ge	32	72,59	937,40
Hydrogen	H	1	1,01	-259,14
Indium	In	49	114,82	156,61
Iodine	I	53	126,90	113,50
Iridium	Ir	77	192,22	2410,00
Ytterbium	Yb	70	173,04	824,00
Yttrium	Y	39	88,91	1523,00
Lanthanum	La	57	138,91	920,00
Lithium	Li	3	6,94	180,54
Lutetium	Lu	71	174,96	1656,00
Magnesium	Mg	12	24,31	638,80
Manganese	Mn	25	54,94	1245,00
Mendelevium	Md	101	258,00	
Mercury	Hg	80	200,59	-38,87
Molybdenum	Mo	42	95,94	2617,00
Neodymium	Nd	60	144,24	1010,00
Neon	Ne	10	20,17	-248,60
Neptunium	Np	93	237,05	640,00
Nickel	Ni	28	58,71	1453,00
Niobium	Nb	41	92,91	2468,00
Nobelium	No	102	259,00	
Holmium	Ho	67	164,93	1470,00
Gold	Au	79	196,97	1064,43
Osmium	Os	76	190,20	3045,00
Oxygen	O	8	16,00	-218,40
Palladium	Pd	46	106,40	1552,00
Lead	Pb	82	207,20	327,50
Platinum	Pt	78	195,09	1772,00
Plutonium	Pu	94	244,00	639,50

Element	Symbol	Atomic N°	Atom. Wgt.	Melt. point °C
Polonium	Po	84	209,00	254,00
Potassium	K	19	39,10	63,65
Praseodymium	Pr	59	140,91	935,00
Promethium	Pm	61	145,00	
Protactinium	Pa	91	231,04	1600,00
Radium	Ra	88	226,03	700,00
Radon	Rn	86	222,00	-71,00
Copper	Cu	29	63,55	1083,00
Rhenium	Re	75	186,21	3180,00
Rhodium	Rh	45	102,91	1966,00
Rubidium	Rb	37	85,47	38,89
Ruthenium	Ru	44	101,07	2250,00
Samarium	Sm	62	150,40	1072,00
Scandium	Sc	21	44,96	1539,00
Selenium	Se	34	78,96	217,00
Silicon	Si	14	28,09	1410,00
Sodium	Na	11	22,99	97,80
Tin	Sn	50	118,69	231,90
Strontium	Sr	38	87,62	769,00
Thallium	Tl	81	204,37	303,50
Tantalum	Ta	73	180,95	2996,00
Technetium	Tc	43	98,91	2200,00
Tellurium	Te	52	127,60	449,50
Terbium	Tb	65	158,93	1360,00
Titanium	Ti	22	47,90	1660,00
Thorium	Th	90	232,04	1750,00
Thulium	Tm	69	168,93	1545,00
Tungsten	W	74	183,85	3410,00
Uranium	U	92	238,03	1132,00
Vanadium	V	23	50,94	1890,00
Xenon	Xe	54	131,30	-111,90
Zinc	Zn	30	65,38	419,58
Zirconium	Zr	40	91,22	1852,00
Sulfur	S	16	32,06	112,80

Specific weight of some substances

SOLIDS	
Aluminium	2,70
Silver	10,50
Diamond	8,51
Pure Iron	7,86
Cast Iron	7,27
Nickel	8,85
Gold	19,33
Brass	8,65
Lead	11,34
Platinum	21,45
Plexiglass	1,18
Copper	8,93

LIQUIDS	
Distilled water	1,00
Ethyl alcohol	0,79
Gasoline	0,68
Mercury	13,60
Linseed Oil	0,93
Petroleum	0,81

GASES	
Acetylene	1,10
Ammonia	0,77
Carbon Dioxide	1,98
Air	1,29
Nitrogen	1,25
Helium	0,18
Ethylene	1,26
Hydrogen	0,09
Methane	0,72
Oxygen	1,43

Class	Behaviour	Effects on Physical Properties	Increase in Volume %	delta Sh.A
●	recommended	small or none	less than 10	less than 10
●	satisfactory	minor	from 10 to 30	from 10 to 20
●	unsatisfactory	moderate	from 30 to 60	from 20 to 30
●	not recommended	severe	greater than 60	greater than 30

- NR** = NATURAL RUBBER
- SBR** = STYRENE-BUTADIENE RUBBER
- EPDM** = ETHYLENE-PROPYLENE THERMOPOLYMER
- NBR** = NITRILE RUBBER
- CR** = POLYCHLOROPRENE
- CSM** = CHLOROSULPHONATED POLYETHYLENE
- VMQ** = SILICONE RUBBER
- FKM** = FLUOROCARBON RUBBER (VITON®)

Acetylene	-	● ● ● ● ● ● ● ●
Acetophenone	-	● ● ● ● ● ● ● ●
Acetone	-	● ● ● ● ● ● ● ●
Acetic Acid	10	● ● ● ● ● ● ● ●
Acetic Acid	50	● ● ● ● ● ● ● ●
Acetic Acid	25	● ● ● ● ● ● ● ●
Acetic Acid	100	● ● ● ● ● ● ● ●
Boric Acid	10	● ● ● ● ● ● ● ●
Citric Acid	SAT	● ● ● ● ● ● ● ●
Chloroacetic Acid	-	● ● ● ● ● ● ● ●
Chromic Acid	40	● ● ● ● ● ● ● ●
Formic Acid	SAT.	● ● ● ● ● ● ● ●
Formic Acid	SAT	● ● ● ● ● ● ● ●
Phosphoric Acid	60	● ● ● ● ● ● ● ●
Hypochlorous Acid	-	● ● ● ● ● ● ● ●
Lactic Acid	-	● ● ● ● ● ● ● ●
Maleic Acid	-	● ● ● ● ● ● ● ●
Naphthenic Acid	-	● ● ● ● ● ● ● ●
Nitric Acid	10	● ● ● ● ● ● ● ●
Nitric Acid	65	● ● ● ● ● ● ● ●
Palmitic Acid	-	● ● ● ● ● ● ● ●
Salicylic Acid	-	● ● ● ● ● ● ● ●
Stearic Acid	-	● ● ● ● ● ● ● ●
Sulfhydic Acid	10	● ● ● ● ● ● ● ●
Sulfhydic Acid	20	● ● ● ● ● ● ● ●
Sulfuric Acid	25	● ● ● ● ● ● ● ●
Sulfuric Acid	50	● ● ● ● ● ● ● ●
Sulfuric Acid	60	● ● ● ● ● ● ● ●
Sulfuric Acid	75	● ● ● ● ● ● ● ●
Sulfuric Acid	96	● ● ● ● ● ● ● ●
Sulfurous Acid	-	● ● ● ● ● ● ● ●
Tannic Acid	-	● ● ● ● ● ● ● ●
Tartaric Acid	10	● ● ● ● ● ● ● ●
Deionized Water	-	● ● ● ● ● ● ● ●
Turpentine	-	● ● ● ● ● ● ● ●
Acrylonitrile	-	● ● ● ● ● ● ● ●
Ammonia	-	● ● ● ● ● ● ● ●
Aniline	-	● ● ● ● ● ● ● ●
Aniline	-	● ● ● ● ● ● ● ●
Asphalt	-	● ● ● ● ● ● ● ●
ASTM 1 OIL	-	● ● ● ● ● ● ● ●
ASTM 2 OIL	-	● ● ● ● ● ● ● ●
ASTM 3 OIL	-	● ● ● ● ● ● ● ●
Benzene	-	● ● ● ● ● ● ● ●
Sodium Bicarbonate	-	● ● ● ● ● ● ● ●
Carbon Dioxide	-	● ● ● ● ● ● ● ●
Butter	-	● ● ● ● ● ● ● ●
Butadiene	-	● ● ● ● ● ● ● ●
Liquid Butane	-	● ● ● ● ● ● ● ●
Fuel A (Isooctane 100%)	-	● ● ● ● ● ● ● ●
Fuel B (Isooct. 70% Toluene 30)	-	● ● ● ● ● ● ● ●
Fuel C (Isooct. 50% Toluene 50)	-	● ● ● ● ● ● ● ●
Fuel with Methanol or Ethanol	-	● ● ● ● ● ● ● ●
Kerosene	-	● ● ● ● ● ● ● ●
Cyclohexane	-	● ● ● ● ● ● ● ●
Chloroacetone	-	● ● ● ● ● ● ● ●

Chloroform	-	● ● ● ● ● ● ● ●
Chloroprene	-	● ● ● ● ● ● ● ●
Dry Chlorine	-	● ● ● ● ● ● ● ●
Wet Chlorine	-	● ● ● ● ● ● ● ●
Dibutyl Phthalate	-	● ● ● ● ● ● ● ●
Diethylene Glycol	-	● ● ● ● ● ● ● ●
Diethyl Sebacate	-	● ● ● ● ● ● ● ●
Dinitrotoluene	-	● ● ● ● ● ● ● ●
Diocetyl Phthalate	-	● ● ● ● ● ● ● ●
Diocetyl Sebacate	-	● ● ● ● ● ● ● ●
Epichlorohydrin	-	● ● ● ● ● ● ● ●
Hexane	-	● ● ● ● ● ● ● ●
Ethanol	-	● ● ● ● ● ● ● ●
Fluorobenzene	-	● ● ● ● ● ● ● ●
Liquid Fluorine	-	● ● ● ● ● ● ● ●
Formaldehyde	40	● ● ● ● ● ● ● ●
Formaldehyde	40	● ● ● ● ● ● ● ●
Freon 11	-	● ● ● ● ● ● ● ●
Freon 12	-	● ● ● ● ● ● ● ●
Freon 21	-	● ● ● ● ● ● ● ●
Freon 22	-	● ● ● ● ● ● ● ●
Freon 113	-	● ● ● ● ● ● ● ●
Freon 114	-	● ● ● ● ● ● ● ●
Glycerine	-	● ● ● ● ● ● ● ●
Silicone Grease	-	● ● ● ● ● ● ● ●
Hydrogen	-	● ● ● ● ● ● ● ●
Calcium Hydroxide	-	● ● ● ● ● ● ● ●
Sodium Hypochlorite	10	● ● ● ● ● ● ● ●
Milk	-	● ● ● ● ● ● ● ●
Mercury	-	● ● ● ● ● ● ● ●
Methanol	-	● ● ● ● ● ● ● ●
Methyl Ethyl Ketone	-	● ● ● ● ● ● ● ●
Naphtha	-	● ● ● ● ● ● ● ●
Nitrobenzene	-	● ● ● ● ● ● ● ●
Nitroethane	-	● ● ● ● ● ● ● ●
Nitromethane	-	● ● ● ● ● ● ● ●
Nitropropane	-	● ● ● ● ● ● ● ●
Animal Oil (Whale-Seal)	-	● ● ● ● ● ● ● ●
Grain Oil	-	● ● ● ● ● ● ● ●
Coconut Oil	-	● ● ● ● ● ● ● ●
Cod-Liver Oil	-	● ● ● ● ● ● ● ●
Olive Oil	-	● ● ● ● ● ● ● ●
Cottonseed Oil	-	● ● ● ● ● ● ● ●
Silicon Oil	-	● ● ● ● ● ● ● ●
Castor Oil	-	● ● ● ● ● ● ● ●
Oxygen	-	● ● ● ● ● ● ● ●
Ozone	-	● ● ● ● ● ● ● ●
Perchloroethylene	-	● ● ● ● ● ● ● ●
Potassium Permanganate	25	● ● ● ● ● ● ● ●
Tetraethyl Lead	-	● ● ● ● ● ● ● ●
Propane	-	● ● ● ● ● ● ● ●
Soda (Sodium Hydroxide)	10	● ● ● ● ● ● ● ●
Styrene	-	● ● ● ● ● ● ● ●
Toluene	-	● ● ● ● ● ● ● ●
Trichloroethylene	-	● ● ● ● ● ● ● ●
Sulfur	-	● ● ● ● ● ● ● ●

The data shown in the table are approximate

ELASTOMERS		NR	SBR	EPDM	NBR	CR	CSM	VMQ	FKM	
Specific weight		0.93	0.95	0.86	0.97	1.25	1.2	1.2	1.82	
Hardness	(Shore A)	25:95	35:95	40:85	30:90	25:90	40:90	30:80	50:90	
Tensile strength	(M Pa)	14:30	7:28	6:18	7:25	7:24	12:24	4:9	5:17	
Ultimate elongation	(%)	150:850	125:850	150:500	150:750	100:800	150:500	400:600	125:300	
Resilience	(%)	30:65	25:55	35:55	10:50	20:50	5:20	40:55	5:10	
Extreme operating temperatures		(°C)	-45:85	-40:90	-40:155	-40:110	-40:100	-15:120	-50:225	-20:250
Abrasion resistance		●	●●	●	●	●●	●●	●	●●	
Gas impermeability		●	●●	●	●●	●	●	●	●	

Class	Behaviour
●	recommended
●	satisfactory
●	unsatisfactory
●	not recommended

- NR** = NATURAL RUBBER
- SBR** = STYRENE-BUTADIENE RUBBER
- EPDM** = ETHYLENE-PROPYLENE THERMOPOLYMER
- NBR** = NITRILE RUBBER
- CR** = POLYCHLOROPRENE
- CSM** = CHLOROSULPHONATED POLYETHYLENE
- VMQ** = SILICONE RUBBER
- FKM** = FLUOROCARBON RUBBER (VITON®)

VITON® is a registered trademark of Dupont Dow Elastomers L.L.C.

Specifications of **TEFLON®** (Virgin PTFE)

Properties	U.m.	Values (from-to)
Specific weight	-	2.14 - 2.20
Ultimate strength	N/mm ²	20 - 35
Ultimate elongation	%	210 - 400
Compressive strength 1% deformat.	N/mm ²	4.00 - 4.50
Flexural strength 0.7 N/mm ²	N/mm ²	no breakage
Shock resistance 57°C	J/cm	1,1
Shock resistance 23°C	J/cm	1,6
Shock resistance 77°C	J/cm	3,3
Hardness	(shoreD)	50 - 60
Static friction coefficient	-	0,09
Dynamic friction coefficient	-	0,05
PTFE - oil-lubricated steel	-	0,02 - 0,06
Coefficient of expansion from 25 to 100°C	°C ⁻¹	16 x 10 ⁻⁵
Thermal conductivity	W/mK	0,2
Distortion temperatures 0.46 N/mm ²	°C	130 - 140
Distortion temperatures 1.85 N/mm ²	°C	50 - 60
Water absorption	%	<0,01
Inflammability ATB	sec	<5,00
Inflammability AEB	mm	<5,00
Operating temperature	°C	-200 +260

The data shown in the table are approximate

TEFLON® is a registered trademark of E.I. Dupont De Nemours & Co.

ISO METRIC		
M		
Thread Diameter	Drill Hole Diameter	
mm	mm	
M 1 x 0,25	0,75	
M 1,1 x 0,25	0,85	
M 1,2 x 0,25	0,95	
M 1,4 x 0,30	1,1	
M 1,6 x 0,35	1,25	
M 1,8 x 0,35	1,45	
M 2 x 0,4	1,6	
M 2,2 x 0,45	1,75	
M 2,5 x 0,45	2,05	
M 3 x 0,5	2,5	
M 3,5 x 0,6	2,9	
M 4 x 0,7	3,3	
M 4,5 x 0,75	3,7	
M 5 x 0,8	4,2	
M 6 x 1	5	
M 7 x 1	6	
M 8 x 1,25	6,8	
M 9 x 1,25	7,8	
M 10 x 1,5	8,5	
M 11 x 1,5	9,5	
M 12 x 1,75	10,2	
M 14 x 2	12	
M 16 x 2	14	
M 18 x 2,5	15,5	
M 20 x 2,5	17,5	
M 22 x 2,5	19,5	
M 24 x 3	21	
M 27 x 3	24	
M 30 x 3,5	26,5	
M 33 x 3,5	29,5	
M 36 x 4	32	
M 39 x 4	35	
M 42 x 4,5	37,5	
M 45 x 4,5	40,5	
M 48 x 5	43	
M 52 x 5	47	
M 56 x 5,5	50,5	

ISO METRIC FINE					
MF					
Thread Diameter	Drill Hole Diameter		Thread Diameter	Drill Hole Diameter	
mm	mm		mm	mm	
M 1 x 0,2	0,75		M 24 x 2	22	
M 1,1 x 0,2	0,9		M 25 x 1	24	
M 1,2 x 0,2	1		M 25 x 1,5	23,5	
M 1,4 x 0,2	1,2		M 25 x 2	23	
M 1,4 x 0,25	1,15		M 26 x 1,5	24,5	
M 1,6 x 0,2	1,4		M 27 x 1	26	
M 1,8 x 0,2	1,6		M 27 x 1,5	25,5	
M 2 x 0,25	1,75		M 27 x 2	25	
M 2,2 x 0,25	1,95		M 28 x 1	27	
M 2,5 x 0,35	2,15		M 28 x 1,5	26,5	
M 3 x 0,35	2,65		M 28 x 2	26	
M 3,5 x 0,35	3,15		M 30 x 1	29	
M 4 x 0,35	3,65		M 30 x 1,5	28,5	
M 4 x 0,5	3,5		M 30 x 2	28	
M 4,5 x 0,5	4		M 30 x 3	27	
M 5 x 0,5	4,5		M 32 x 1,5	30,5	
M 5,5 x 0,5	5		M 32 x 2	30	
M 6 x 0,75	5,2		M 33 x 1,5	31,5	
M 7 x 0,75	6,2		M 33 x 2	31	
M 8 x 1	7		M 33 x 3	30	
M 8 x 0,75	7,2		M 35 x 1,5	33,5	
M 9 x 1	8		M 36 x 1,5	34,5	
M 9 x 0,75	8,2		M 36 x 2	34	
M 10 x 1	9		M 36 x 3	33	
M 10 x 0,75	9,2		M 38 x 1,5	36,5	
M 10 x 1,25	8,8		M 39 x 1,5	37,5	
M 11 x 1	10		M 39 x 2	37	
M 11 x 0,75	10,2		M 39 x 3	36	
M 12 x 1	11		M 40 x 1,5	38,5	
M 12 x 1,25	10,8		M 40 x 2	38	
M 12 x 1,5	10,5		M 40 x 3	37	
M 14 x 1	13		M 42 x 1,5	40,5	
M 14 x 1,25	12,8		M 42 x 2	40	
M 14 x 1,5	12,5		M 42 x 3	39	
M 15 x 1	14		M 42 x 4	38	
M 15 x 1,5	13,5		M 45 x 1,5	43,5	
M 16 x 1	15		M 45 x 2	43	
M 16 x 1,5	14,5		M 45 x 3	42	
M 17 x 1	16		M 45 x 4	41	
M 17 x 1,5	15,5		M 48 x 1,5	46,5	
M 18 x 1	17		M 48 x 2	46	
M 18 x 1,5	16,5		M 48 x 3	45	
M 18 x 2	16		M 48 x 4	44	
M 20 x 1	19		M 50 x 1,5	48,5	
M 20 x 1,5	18,5		M 50 x 2	48	
M 20 x 2	18		M 50 x 3	47	
M 22 x 1	21		M 52 x 1,5	50,5	
M 22 x 1,5	20,5		M 52 x 2	50	
M 22 x 2	20		M 52 x 3	49	
M 24 x 1	23		M 52 x 4	48	
M 24 x 1,5	22,5				

WHITWORTH W BSW	
Nominal Thread Diameter	Drill Hole Diameter
Inches	mm
1/8 - 40	2,55
5/32 - 32	3,2
3/16 - 24	3,7
1/4 - 20	5,1
5/16 - 18	6,5
3/8 - 16	7,9
7/16 - 14	9,2
1/2 - 12	10,5
9/16 - 12	12
5/8 - 11	13,5
3/4 - 10	16,25
7/8 - 9	19,25
1 - 8	21,75
1 1/8 - 7	24,75
1 1/4 - 7	27,75
1 3/8 - 6	30,5
1 1/2 - 6	33,5
1 5/8 - 5	35,5
1 3/4 - 5	39
2 - 4 1/2	44,5
2 1/4 - 4	50
2 1/2 - 4	56,5
2 3/4 - 3 1/2	62
3 - 3 1/2	62

WHITWORTH GAS BSP	
Nominal Thread Diameter	Drill Hole Diameter
Inches	mm
G 1/8 - 28	8,8
G 1/4 - 19	11,8
G 3/8 - 19	15,25
G 1/2 - 14	19
G 5/8 - 14	21
G 3/4 - 14	24,5
G 7/8 - 14	28,25
G 1 - 11	30,75
G 1 1/8 - 11	35,3
G 1 1/4 - 11	39,25
G 1 3/8 - 11	41,9
G 1 1/2 - 11	45,25
G 1 3/4 - 11	51,3
G 2 - 11	57
G 2 1/4 - 11	63,1
G 2 1/2 - 11	72,6
G 2 3/4 - 11	79,1
G 3 - 11	85,5
G 3 1/4 - 11	91,5
G 3 1/2 - 11	97,7
G 3 3/4 - 11	104
G 4 - 11	110,5

TAPERED GAS BSPT	
Nominal Thread Diameter	Drill Hole Diameter
Inches	mm
1/8 - 28	8,4
1/4 - 19	11,2
3/8 - 19	14,75
1/2 - 14	18,25
3/4 - 14	23,75
1 - 11	30
1 1/4 - 11	38,5
1 1/2 - 11	44,5
2 - 11	56
2 1/2 - 11	71,5

UNIFIED COARSE THREAD UNC	
Nominal Thread Diameter	Drill Hole Diameter
Inches	mm
Nr. 1 - 64	1,5
Nr. 2 - 56	1,8
Nr. 3 - 48	2,02
Nr. 4 - 40	2,25
Nr. 5 - 40	2,6
Nr. 6 - 32	2,75
Nr. 8 - 32	3,4
Nr. 10 - 24	3,8
Nr. 12 - 24	4,5
1/4 - 20	5,1
5/16 - 18	6,5
3/8 - 16	8
7/16 - 14	9,4
1/2 - 13	10,75
9/16 - 12	12,2
5/8 - 11	13,6
3/4 - 10	16,5
7/8 - 9	19,5
1 - 8	22,25
1 1/8 - 7	25
1 1/4 - 7	28,25
1 3/8 - 6	30,75
1 1/2 - 6	34
1 3/4 - 5	39,5
2 - 4 1/2	45

UNIFIED COARSE THREAD UNF	
Nominal Thread Diameter	Drill Hole Diameter
Inches	mm
Nr. 0 - 80	1,25
Nr. 1 - 72	1,55
Nr. 2 - 64	1,85
Nr. 3 - 56	2,1
Nr. 4 - 48	2,35
Nr. 5 - 44	2,65
Nr. 6 - 40	2,9
Nr. 8 - 36	3,5
Nr. 10 - 32	4,1
Nr. 12 - 28	4,6
1/4 - 28	5,5
5/16 - 24	6,9
3/8 - 24	8,5
7/16 - 20	9,9
1/2 - 20	11,5
9/16 - 18	12,9
5/8 - 18	14,5
3/4 - 16	17,5
7/8 - 14	20,5
1 - 12	23,25
1 1/8 - 12	26,5
1 1/4 - 12	29,75
1 3/8 - 12	33
1 1/2 - 12	36

AMERICAN NPT	
Nominal Thread Diameter	Drill Hole Diameter
Inches	mm
1/6 - 27	6,25
1/8 - 27	8,5
1/4 - 18	11
3/8 - 18	14,5
1/2 - 14	18
3/4 - 14	23
1 - 11 1/2	29
1 1/4 - 11 1/2	38
1 1/2 - 11 1/2	44
2 - 11 1/2	56
2 1/2 - 8	67

AMERICAN NPTF	
Nominal Thread Diameter	Drill Hole Diameter
Inches	mm
1/6 - 27	6,15
1/8 - 27	8,4
1/4 - 18	10,9
3/8 - 18	14,25
1/2 - 14	17,75
3/4 - 14	23
1 - 11 1/2	29
1 1/4 - 11 1/2	37,75
1 1/2 - 11 1/2	43,75
2 - 11 1/2	55,75
2 1/2 - 8	66,5

DRILL HOLES FOR ROLL FORM TAPS

ISO METRIC M		
Thread Diameter	Drill Hole Diameter	
mm	mm	
M 1 x 0.25	0,9	
M 1,2 x 0.25	1,1	
M 1,4 x 0,3	1,25	
M 1,6 x 0.35	1,45	
M 1,8 x 0.35	1,65	
M 2 x 0.4	1,8	
M 2,5 x 0.45	2,3	
M 3 x 0,5	2,8	
M 3,5 x 0,6	3,2	
M 4 x 0,7	3,7	
M 5 x 0,8	4,6	
M 6 x 1	5,5	
M 7 x 1	6,5	
M 8 x 1.25	7,4	
M 10 x 1,5	9,3	
M 12 x 1.75	11,2	
M 14 x 2	13	
M 16 x 2	15	

UNIFIED COARSE THREAD UNC		
Nominal Thread Diameter	Drill Hole Diameter	
Inches	mm	
Nr. 1 - 64	1,7	
Nr. 2 - 56	2	
Nr. 3 - 48	2,3	
Nr. 4 - 40	2,6	
Nr. 5 - 40	2,9	
Nr. 6 - 32	3,2	
Nr. 8 - 32	3,8	
Nr. 10 - 24	4,4	
Nr. 12 - 24	5	
1/4 - 20	5,8	
5/16 - 18	7,3	
3/8 - 16	8,8	
7/16 - 14	10,3	
1/2 - 13	11,9	

ISO METRIC FINE MF		
Thread Diameter	Drill Hole Diameter	
mm	mm	
M 4 x 0.5	3,5	
M 5 x 0,5	4,5	
M 6 x 0.75	5,2	
M 8 x 0.75	7,2	
M 8 x 1	7,2	
M 10 x 1	9	
M 10 x 1.25	8,8	
M 12 x 1	11	
M 12 x 1.25	10,8	
M 12 x 1.5	10,5	
M 14 x 1	13	
M 14 x 1.25	12,8	
M 14 x 1,5	12,5	
M 16 x 1	15	
M 16 x 1,5	14,5	

UNIFIED COARSE THREAD UNF		
Nominal Thread Diameter	Drill Hole Diameter	
Inches	mm	
Nr. 1 - 72	1,7	
Nr. 2 - 64	2	
Nr. 3 - 56	2,3	
Nr. 4 - 48	2,6	
Nr. 5 - 44	2,9	
Nr. 6 - 40	3,2	
Nr. 8 - 36	3,9	
Nr. 10 - 32	4,5	
Nr. 12 - 28	5,1	
1/4 - 28	6	
5/16 - 24	7,5	
3/8 - 24	9,1	
7/16 - 20	10,6	
1/2 - 20	12,1	

VIVOIL OLEODINAMICA VIVOLO

s.r.l. Società a Socio Unico

Via Leone Ginzburg 2-4 - 40054 Cento di Budrio (BO) - ITALY - TEL. +39 - 051.803689 Fax +39 - 051.800061

Partita Iva e cod. Fiscale 03542620376 C.C.I.A.A. 299009 - Iscr. Trib.: BO 43434

WEB: www.vivoil.com E-mail vivoil@vivoil.com

®

